

Overview of Deepwater Drilling and Production Risers

by Paul Stanton
February 14, 2006



Technip

Riser Types

- Marine drilling risers (MODU risers)
- Top-tensioned risers (TTRs or dry tree risers)
 - ➔ Drilling
 - ➔ Production
- Compliant risers
 - ➔ Steel catenary risers (SCRs)
 - ➔ Flexible risers
- Hybrid Risers

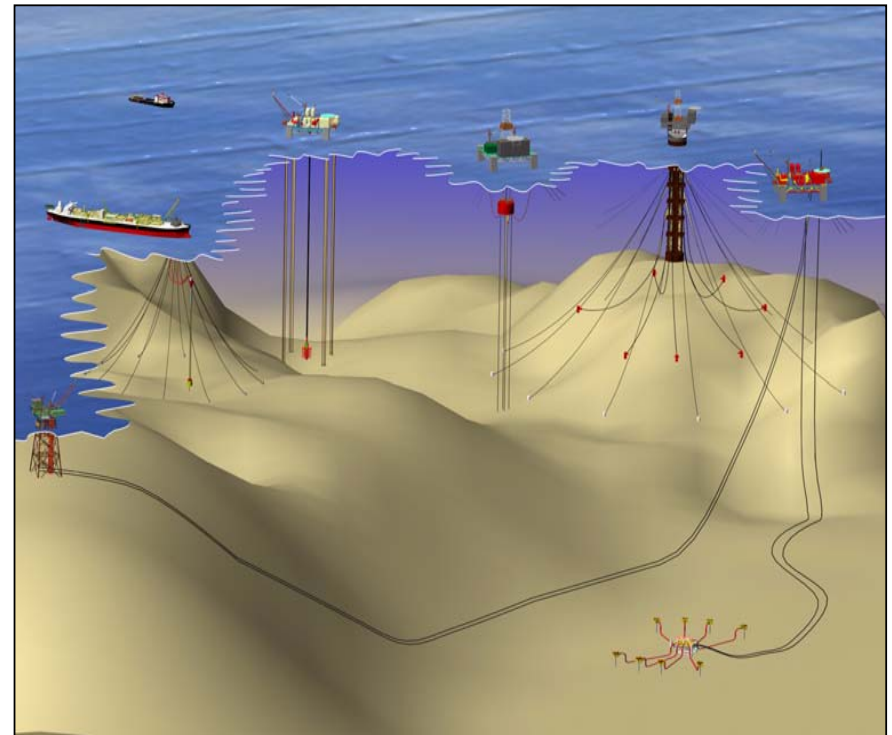

Riser Types: Marine Drilling Riser

Riser Joint

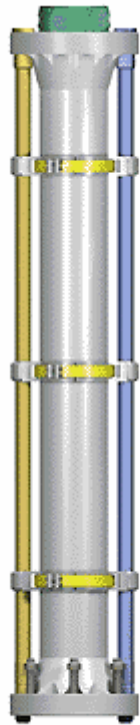

RF Riser Joint



Riser System

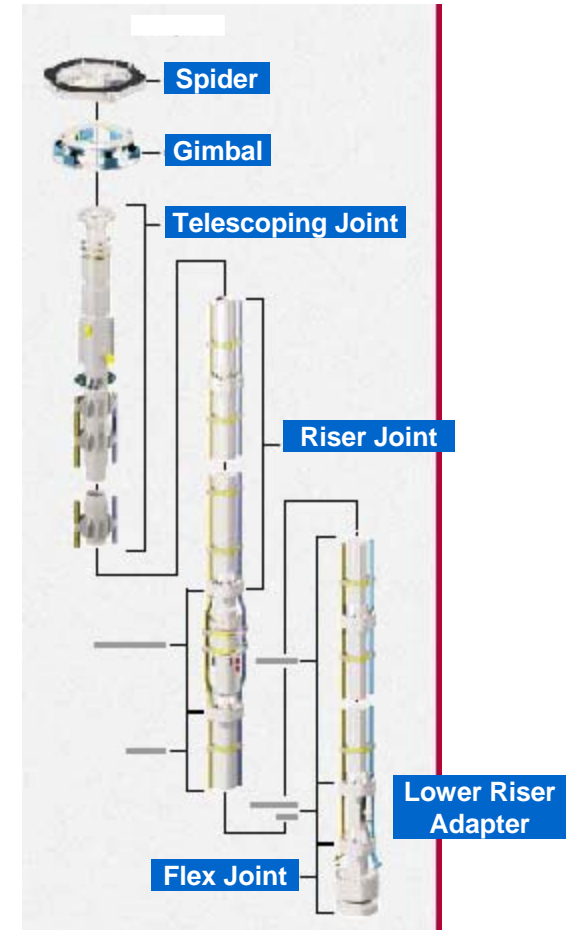

Top-Tensioned Risers on Floating Production Platforms

● Tensioned

→ To avoid buckling and excessive bending stress due to platform motion and VIV

● Reasons for using Top Tensioned Riser (TTR)

→ Reduce drilling and completion costs

→ Complicated completions

→ Heavy workover requirements

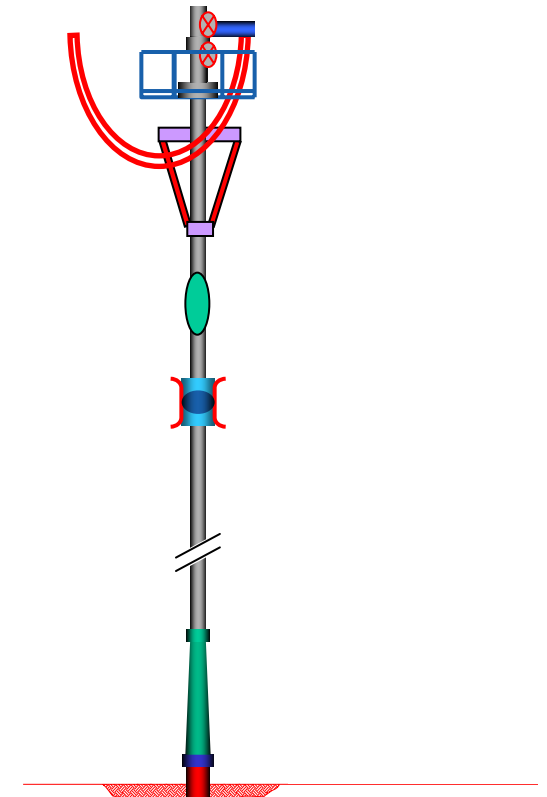
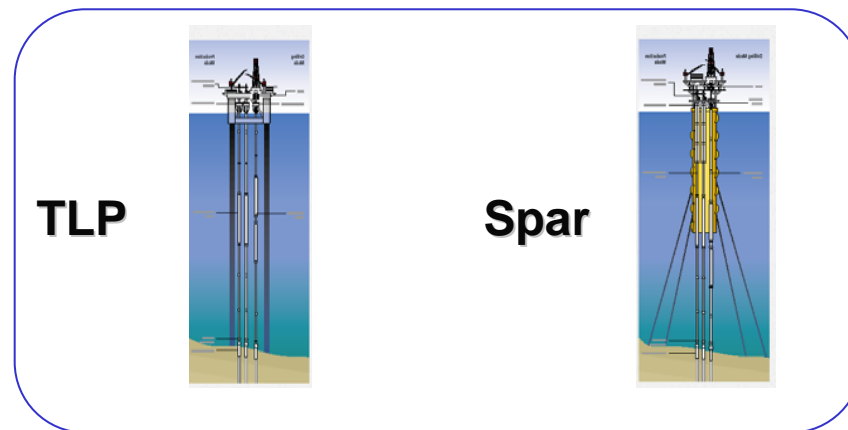

Top-Tensioned Risers

- Requires a platform with good motion response characteristics
 - ➔ **Tension Leg Platform (TLP)**
 - Negligible heave (0 to 1 feet)
 - ➔ **Spar Platform**
 - Small heave (0.5 to 12 feet)

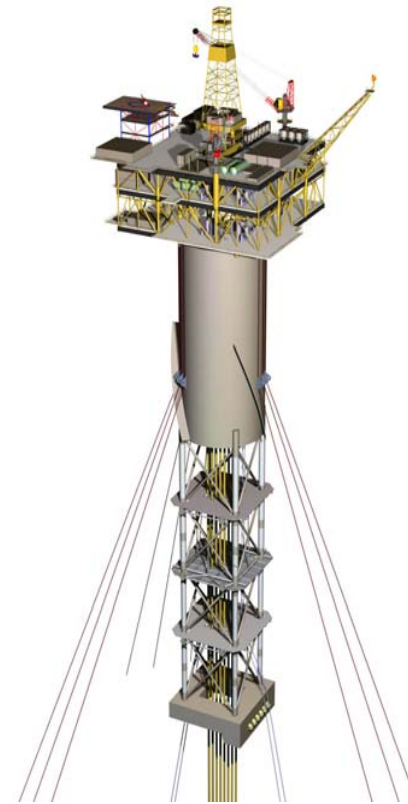

Buoyancy Can Riser Tensioner Systems

● Buoyancy Can Tensioning Systems

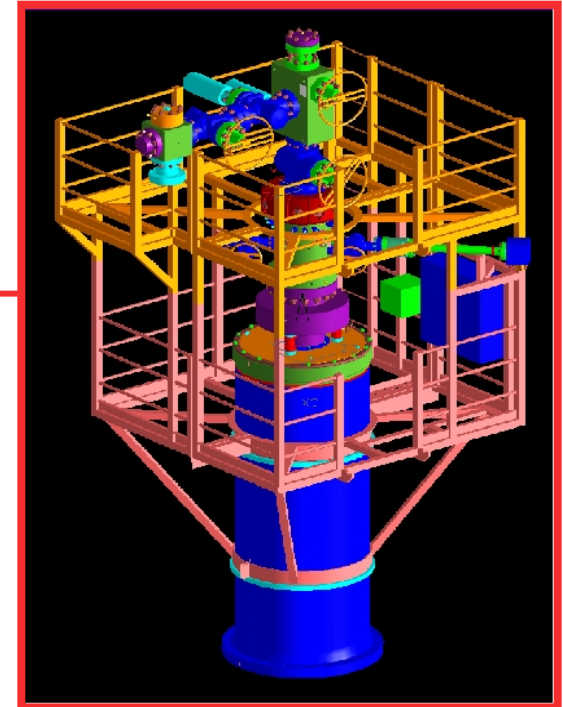
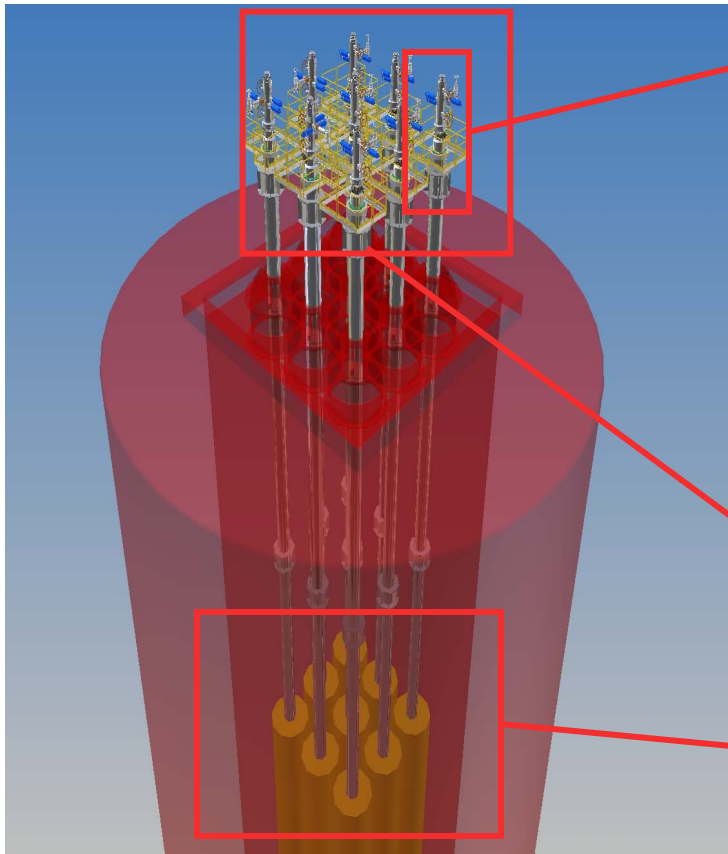

Tensioner-Supported TTR

● Hydro-pneumatic tensioner

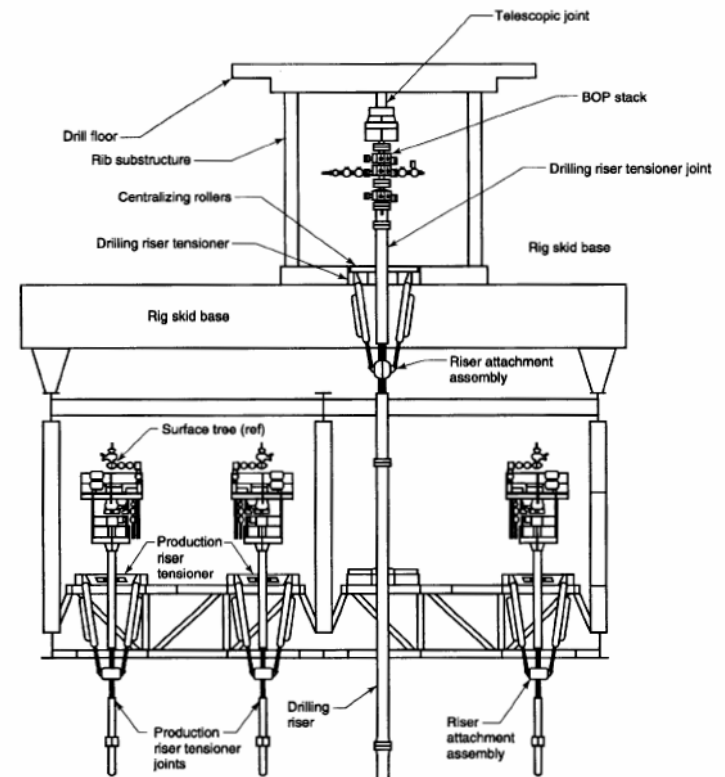
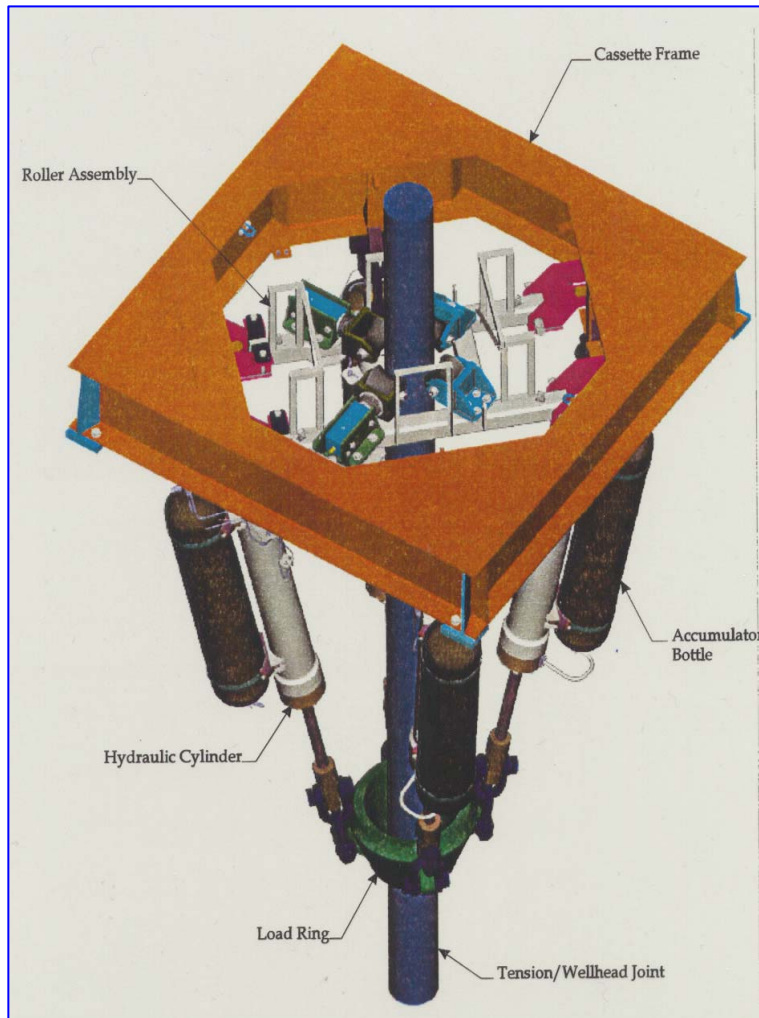

Spar TTRs

- Hydraulic Tensioner Systems

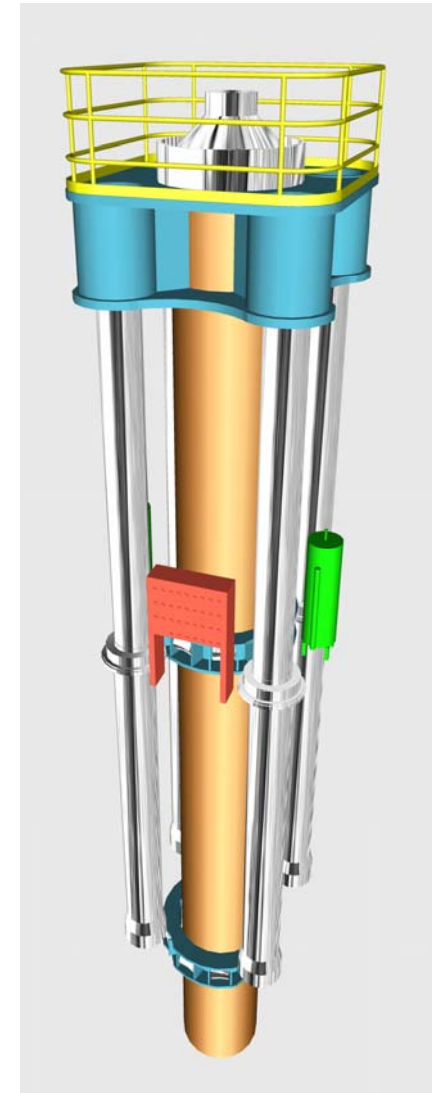
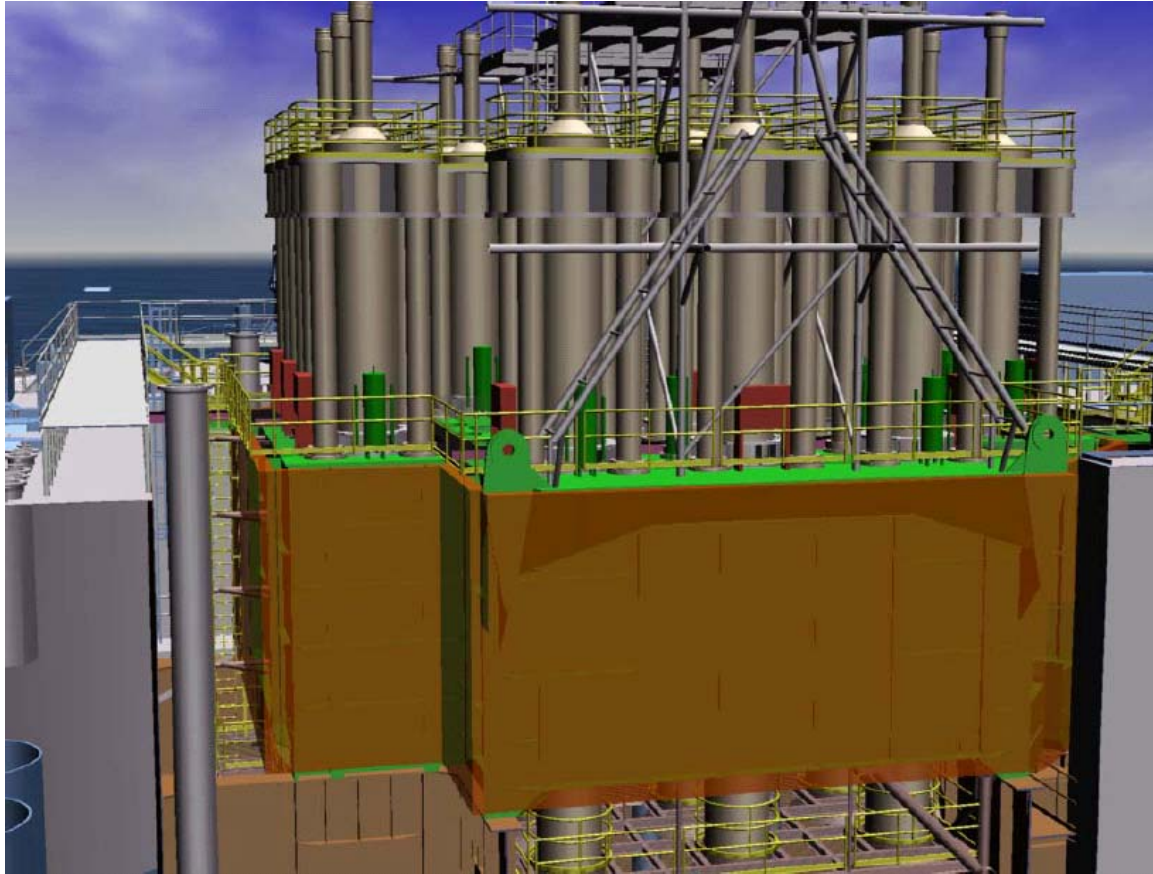

Compliant Risers

Nominal top tension is determined by hanging weight to first sagbend and by hang-off angle

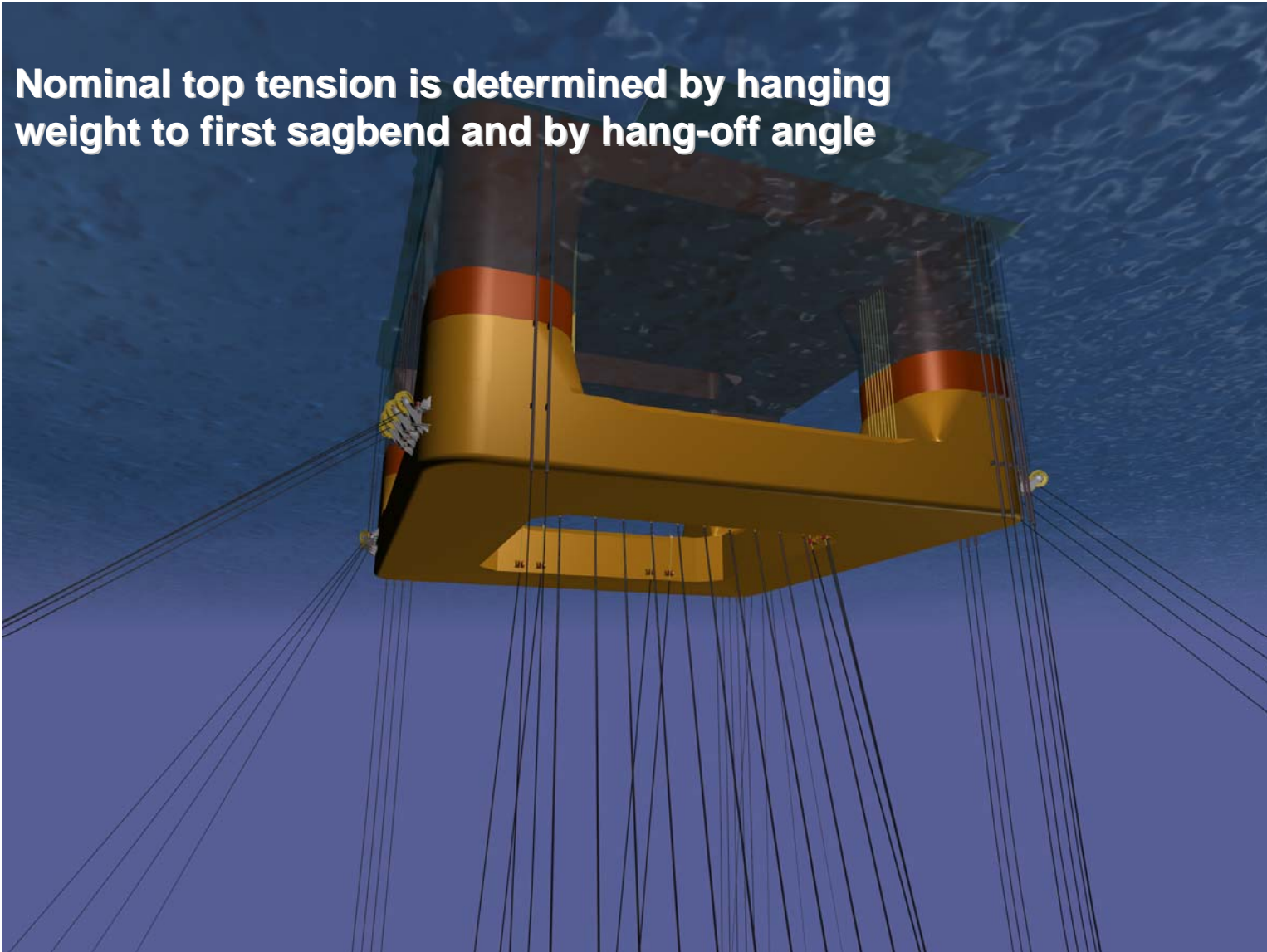

Spar SCR

- Pull-Tube (**Patent Granted**)
- Flex Joint
- Taper Stress Joint

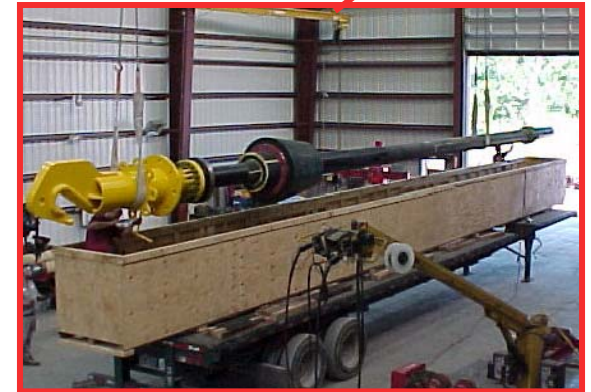
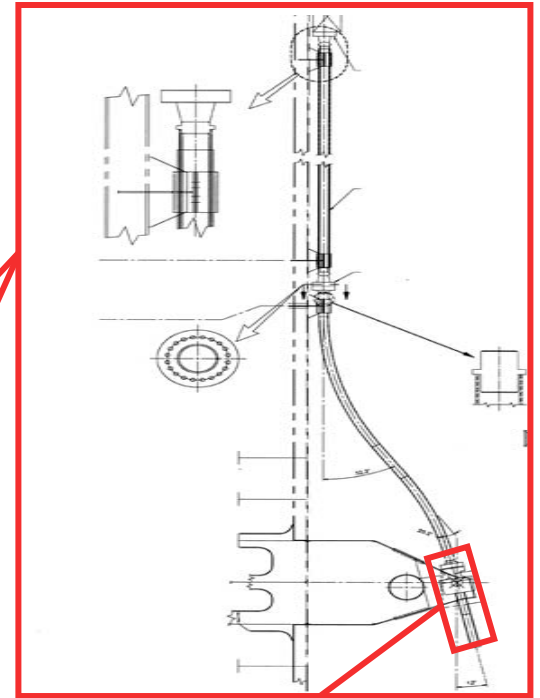
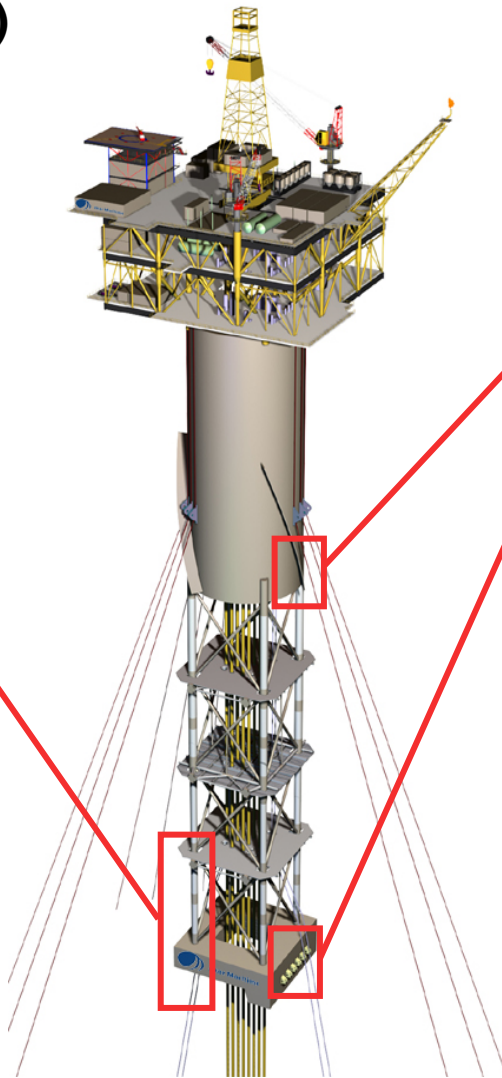

Technip

Compliant Riser - Construction Types

Steel

- Typical material grades are X60, X65, or X70
- Hang-off angles are typically 8 to 20 degrees

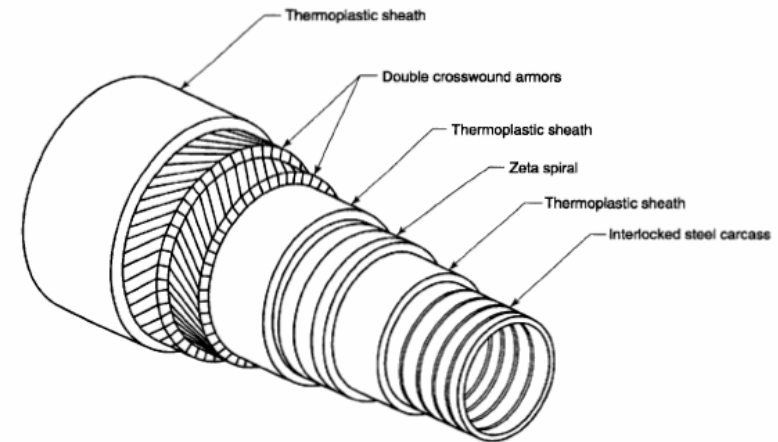

Flexible

- Constructed of layers of steel wire and polymer
- Hang-off angles are typically 5 to 6 degrees

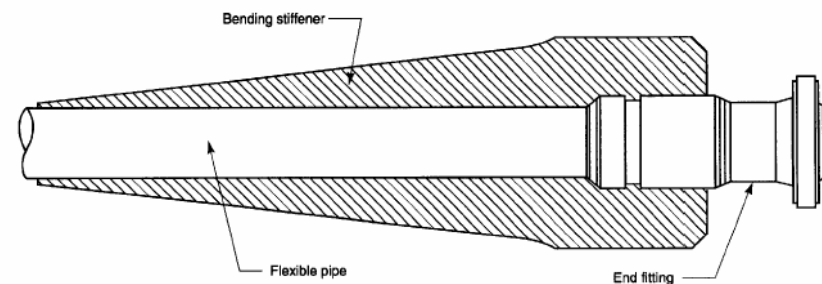

Hybrid Riser

**FPSO
Tieback
(Girasoll)**

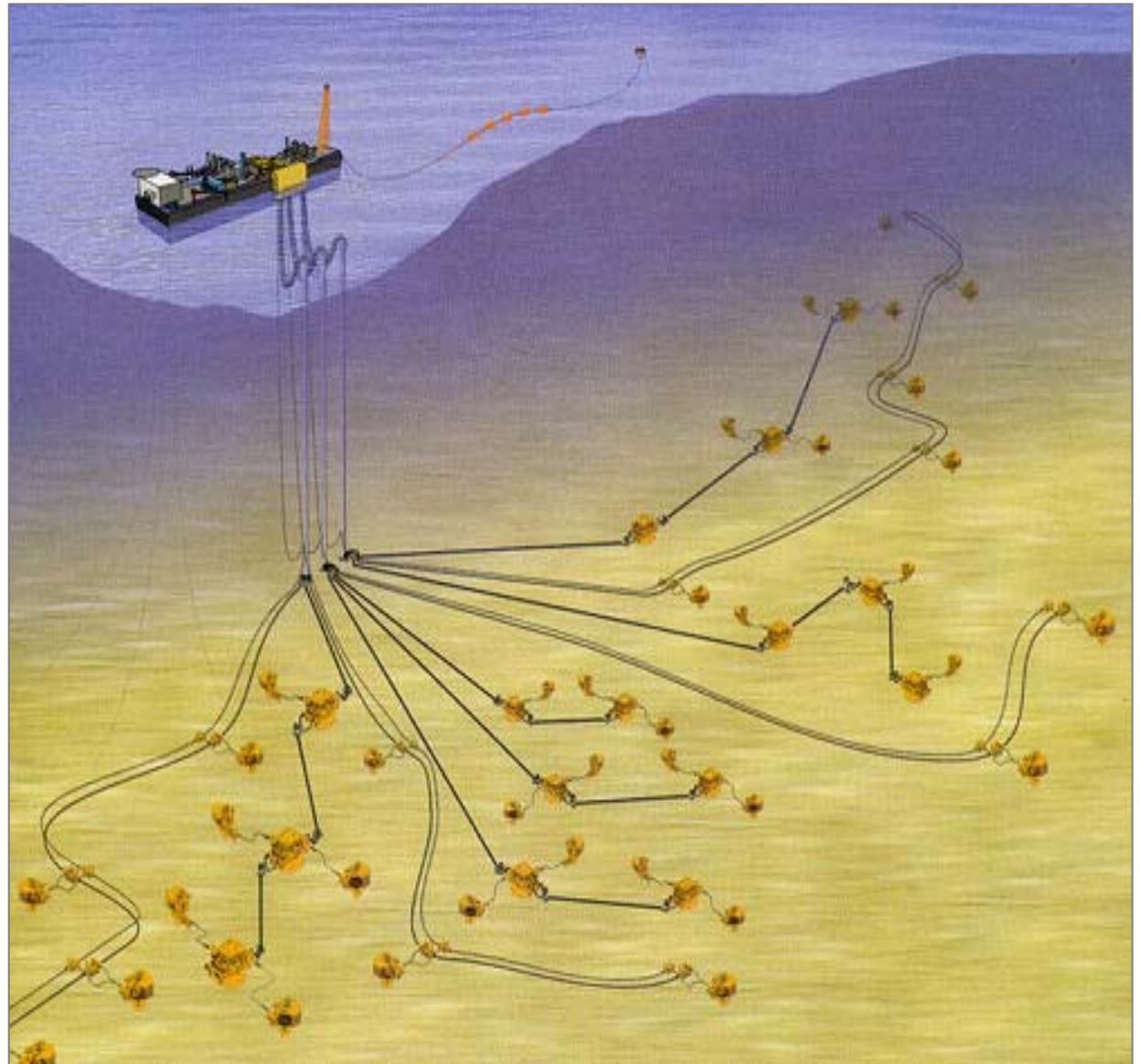

Hybrid Riser

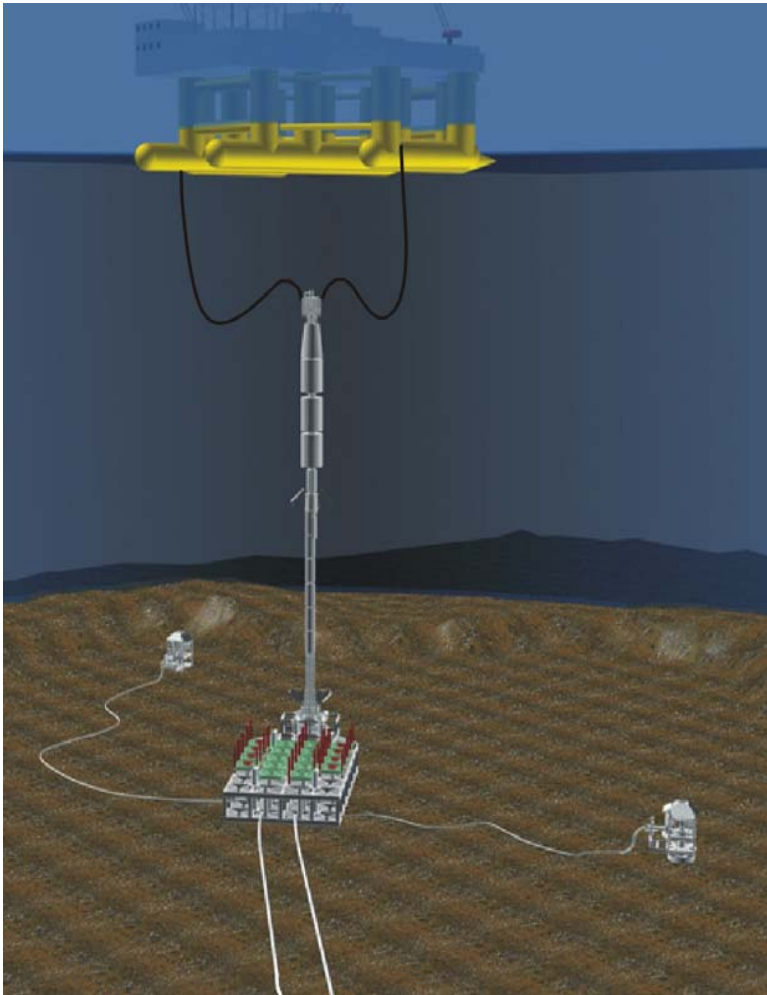

GC 29

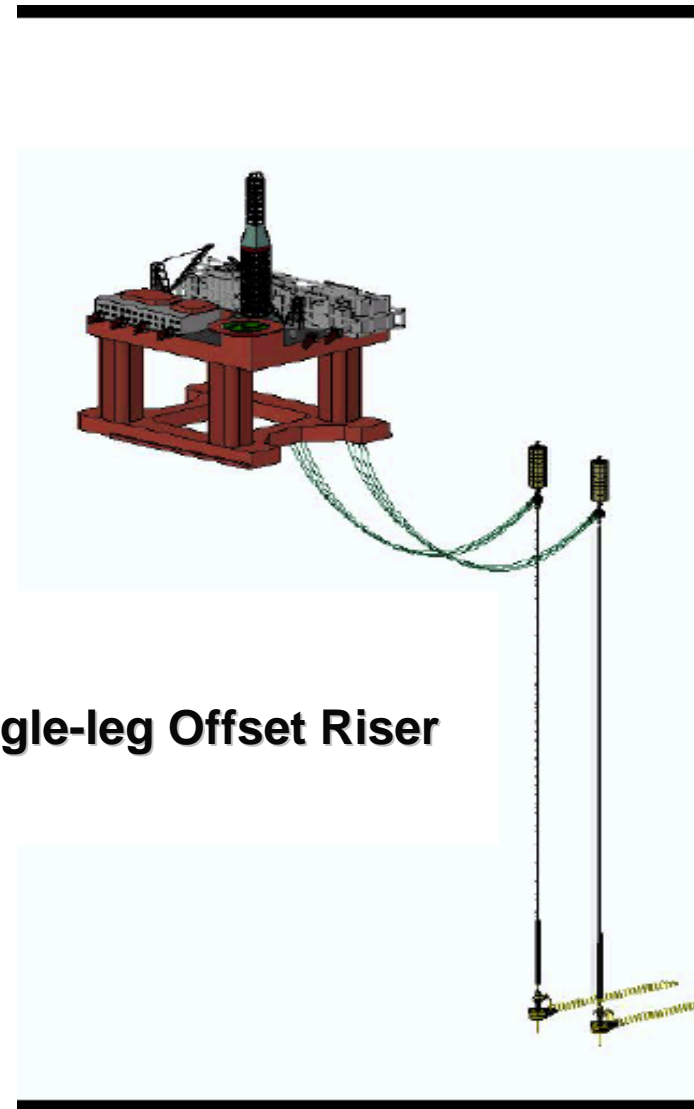

Single-leg Offset Riser

Cost Comparison

- **Must be site specific**
 - **Number of wells**
 - **Host facility nearby with spare capacity**
 - **Environment**
 - **Market**
 - **Meaningless to compare cost of riser types without system costs**



Cost Comparison

● Dry Tree – 33

- PDQ
 - Spars – 4
 - TLPs – 12
- PQ with W/O
 - Spars – 9
 - TLPs – 6
- PQ with TAD
 - Spars – 1
 - TLPs – 1

● Wet Tree – 35

- PQ
 - FPSO – 15
 - Semis – 16
 - TLPs – 3
 - Spars – 1
- PDQ
 - Semis – 1



Typical Field Development Costs

GOM Deepwater: 300 MB, 150 KBD, 20 Wells

<u>Subsea Case</u>	<u>Millions</u>	
• Transportation by Pipeline	\$100	
• Drilling by MODU	\$1000	55 %
• SURF	\$300	
• Topsides	\$250	
• Platform	\$150	8 %
<hr/>		
• Total	\$1800	

MODU vs. DTU Drilling Comparison

Drill From DTU to Reduce Costs

GOM Deepwater: 300 MB, 150 KBD, 20 Wells

	<u>Subsea</u>	<u>Complete</u>	<u>Drill & Comp</u>
• Transportation	\$100	\$100	\$100
• Drilling	\$600	\$600	\$240
• Complete	\$400	\$160	\$160
• SURF	\$300	\$100	\$100
• Topsides	\$250	\$250	\$250
• Platform	\$150	\$180	\$220
Total	\$1800	\$1400	\$1070

Questions?