



AXIOM
Process Ltd

For Further Information please contact:

support@axiomprocess.com

or

rminton@axiomprocess.com

Designer Fluids – Stress Cage concept

A ‘Designer’ Fluid uses ‘sized’ material to bridge fractures and pore spaces, with the objective of increasing the near-wellbore Hoop Stresses.

- This allows higher fluid densities, above the fracture gradient, to be employed
 - Reduced whole fluid losses in depleted zones
 - Reduced number of casing runs
 - Increased margin of safety

The Current Option

Conventional Shaker

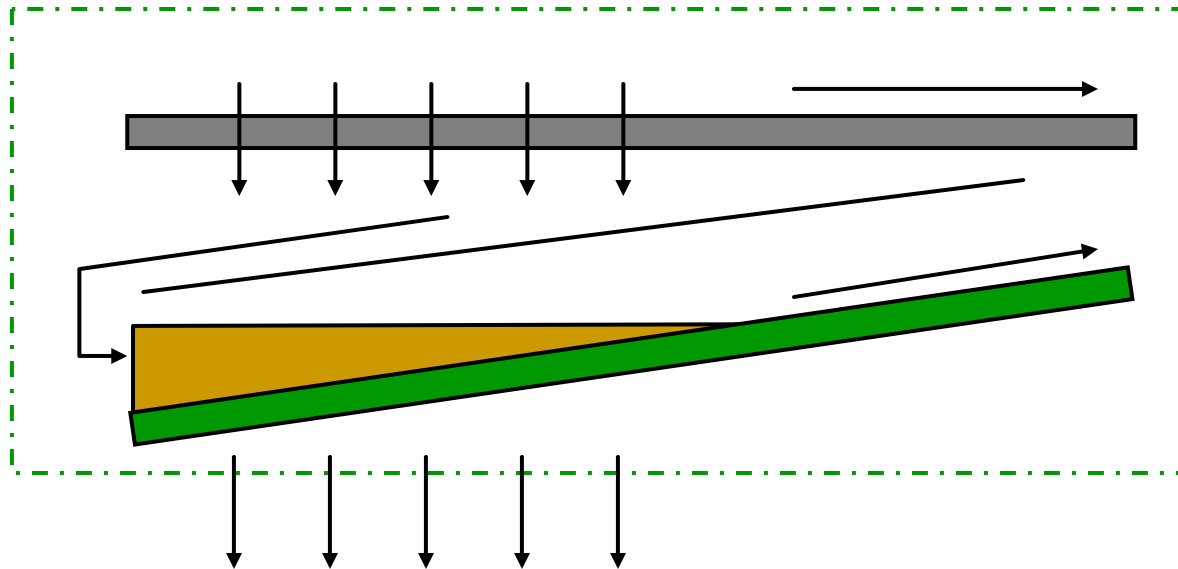

Problem

- Remove the 'sized' material – **Costly**
- Leave the 'sized' material – **Rheology kills You**

The AX-1 Concept

Designer Fluids

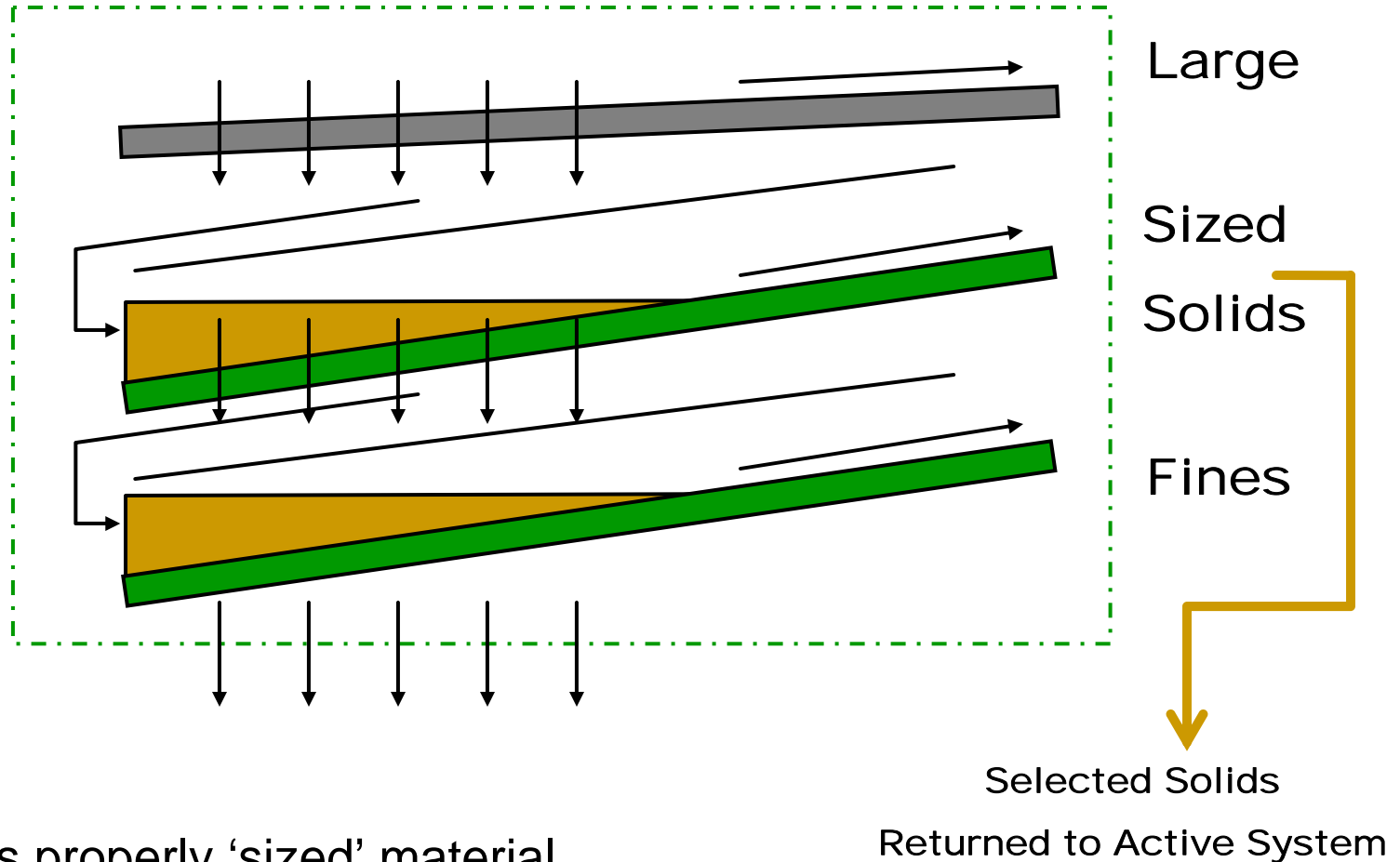

Objectives

- Re-uses properly 'sized' material
- Maintains rheology & removes wrongly 'sized' material

LCM / Bridging Particle Recovery

AXIOM

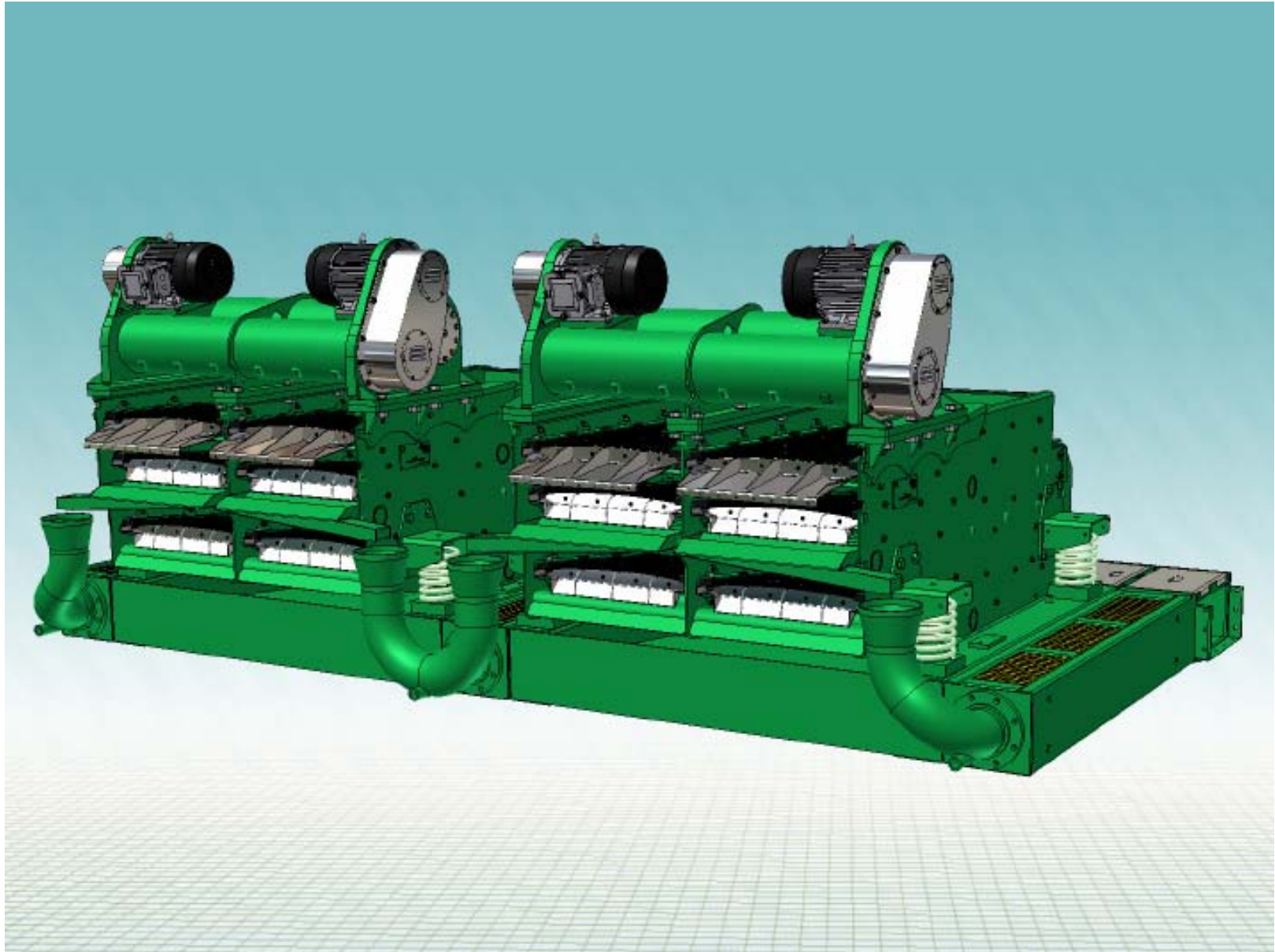

LCM / Bridging Particle Recovery

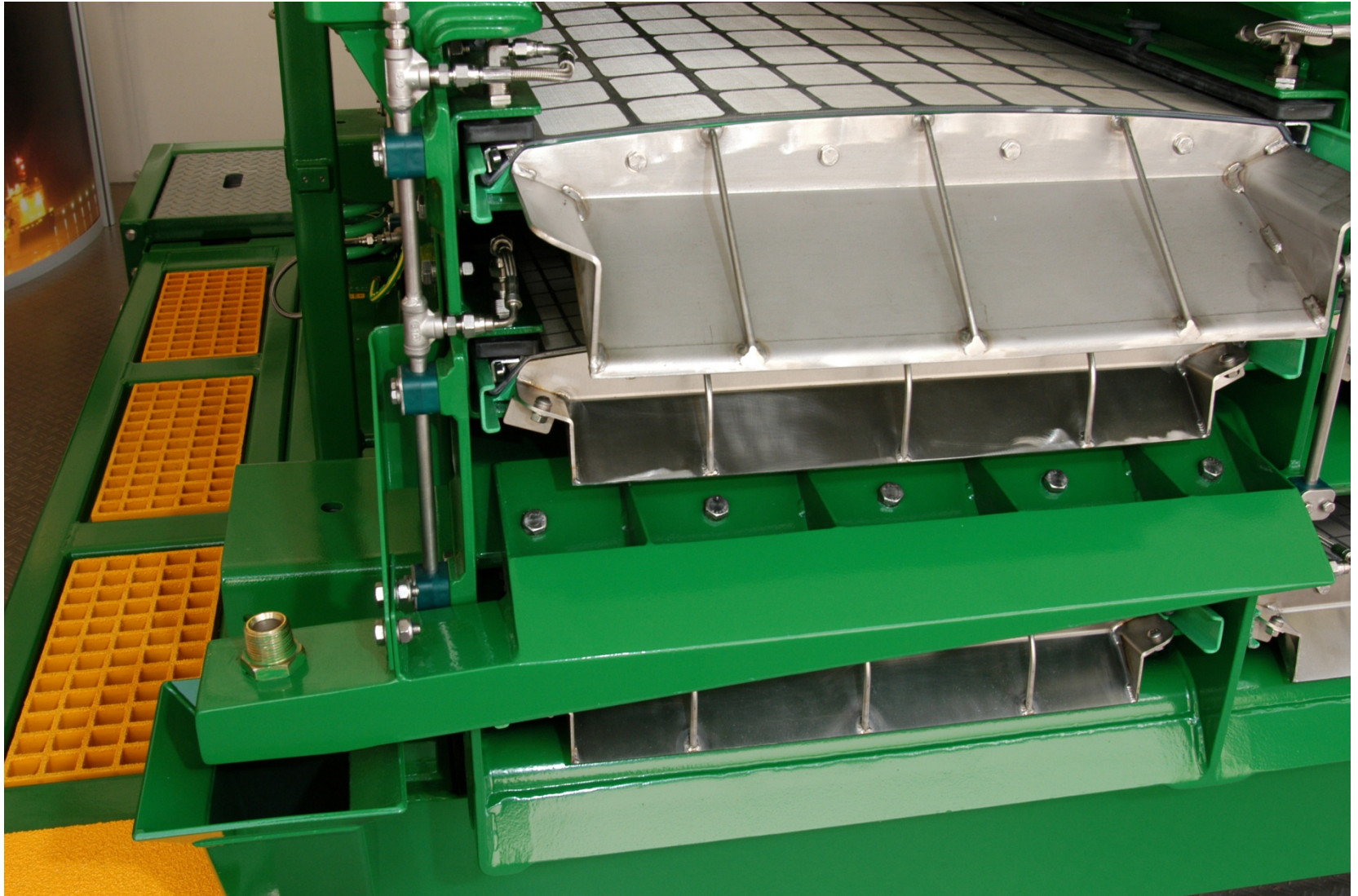

- LCM Recovery Trial
 - Land Rig, South Texas, USA
 - 2 Single Deck Shakers Replaced with 2 Axiom AX-1 Shale Shakers
 - Shakers Previously Dressed with 24 Mesh Screens to remove the Large Formation Cuttings.
 - 12 1/4", 9 7/8" & 6" Sections
 - Graphitic Carbon & Calcium Carbonate Used as LCM

➤ LCM Recovery Trial

- Axiom AX-1 Dressed with 20 or 40 Mesh on Top Screen, 84 Mesh on the Middle Deck and 210 Mesh on the Bottom Deck
- 75 to 80% of Material Recovered in 12 ¼" Hole was LCM Material
- Circa 85% of Material Recovered in 8½" & 6" Hole was LCM Material.
- Significant Reduction in Plastic Vis
- Significant Reduction in Dilution Rates
- Significant Reduction in Drilling Fluid Conditioning Costs.
- Operator Reviewing Options for Other Operating Areas.

LCM / Bridging Particle Recovery



LCM Particle Recovery

AXIOM

