

Are You Buying Too Much Friction Reducer Because of Your Biocide?

Shawn M. Rimassa, Paul R. Howard, Michael O. Arnold, Schlumberger

Fluids Management Study Group Meeting

March 24, 2009

Introduction

- Fluid Components
- Water Effects
- Laboratory Study
- Field Example
- Optimal Fluid

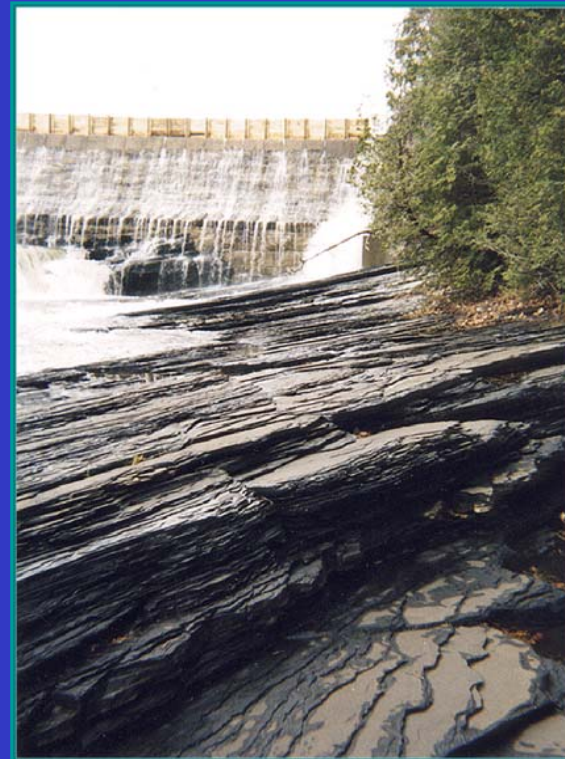

Slickwater Components

- **Friction Reducer**
 - Polymers that reduce the pipe friction during treatment
 - **Biocide**
 - Small molecules that inhibit growth and kill bacteria
 - **Scale Inhibitor**
 - Reactive chemicals that prevent inorganic crystal growth
- ⇒ *Water composition dictates effectiveness and interactions*

Water Effects

Scenario 1:
Fresh Water

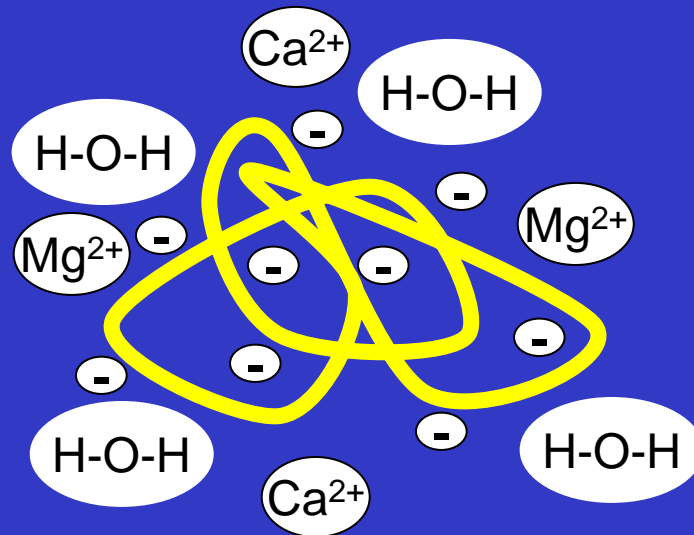
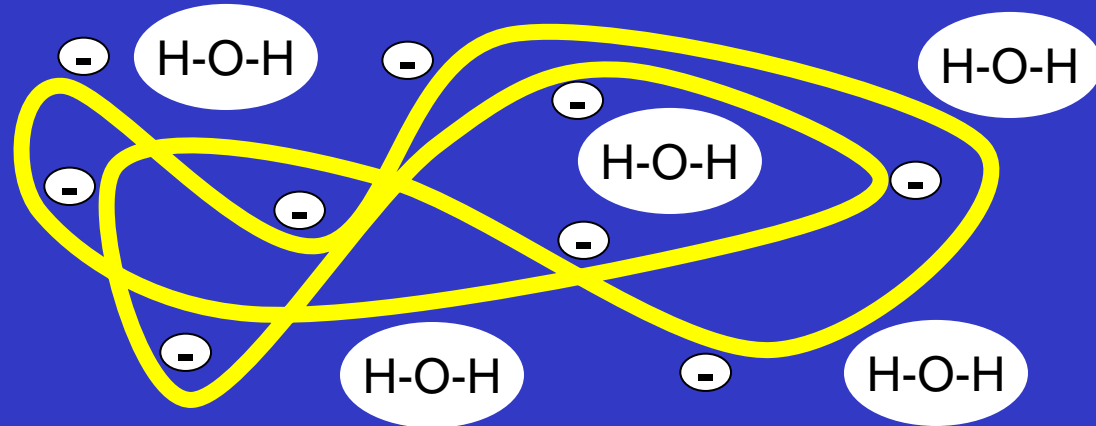

Scenario 2:
Salty Water

Water Quality

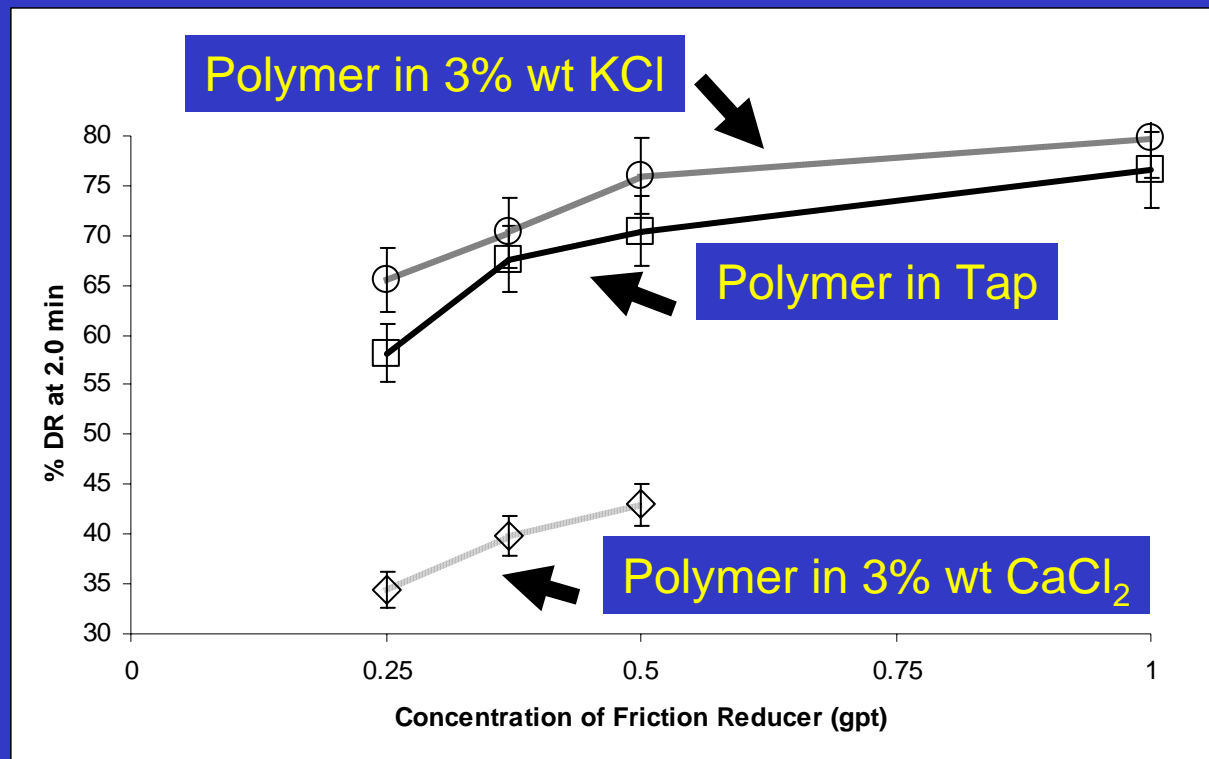

The presence of Ca^{2+} reduces the efficiency of the polymer by half.

Additive Reactions

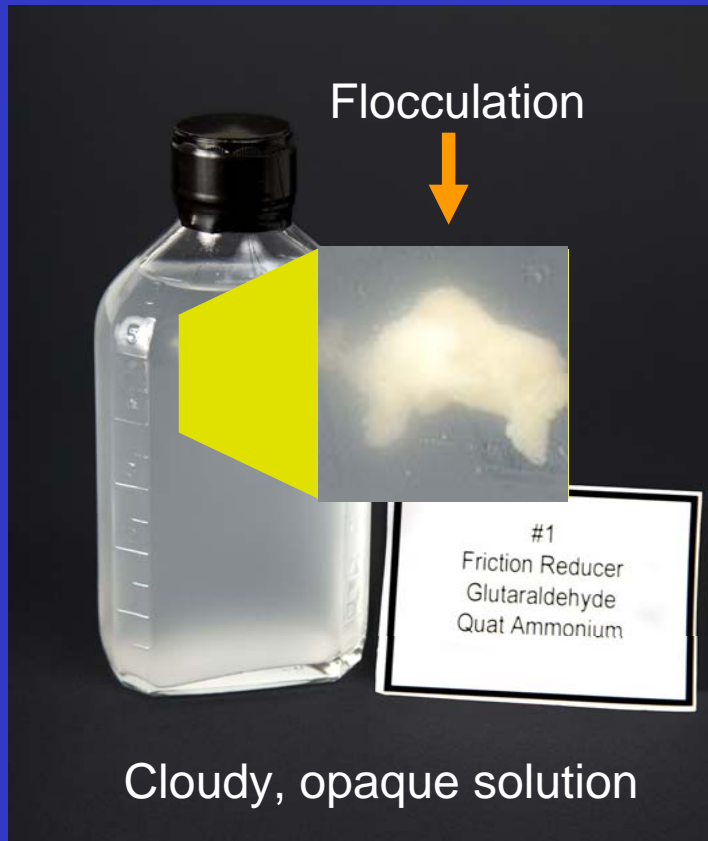

The combination of incompatible additives can form a stable precipitate, thereby negating the effectiveness of **BOTH** products.

Slickwater Chemistry

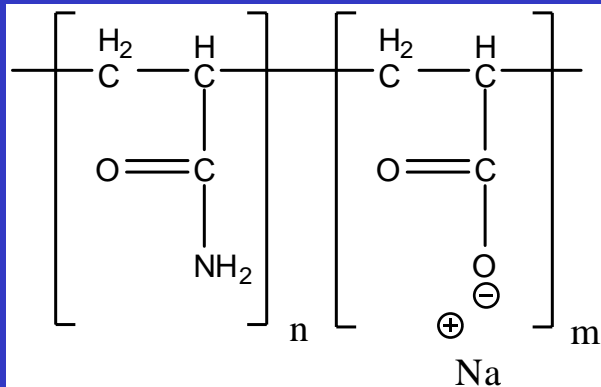

Polyacrylamide

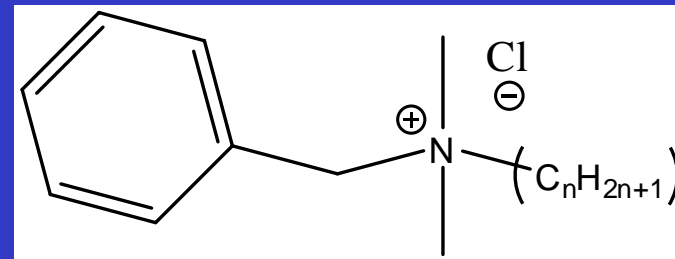

Dialkyl Quaternary Ammonium
(ADBAC)

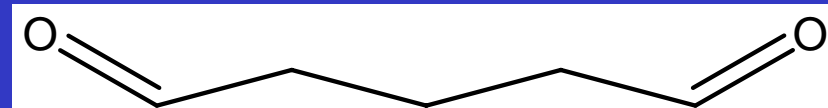

Glutaraldehyde

Effects on Drag Reduction

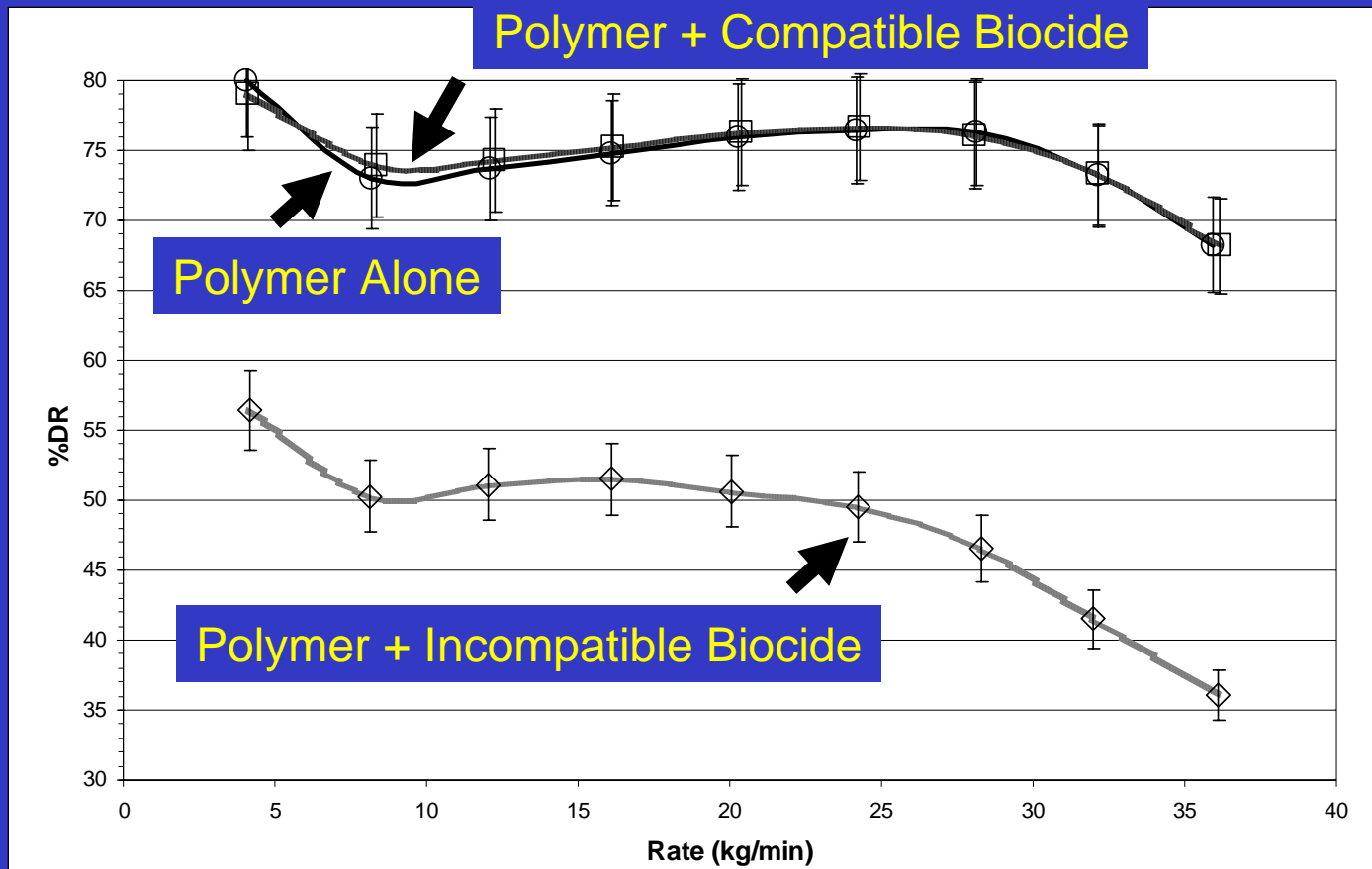

The presence of the incompatible biocide reduces the efficiency of the fluid by 1/3 of the base fluid.

Masking Incompatibility

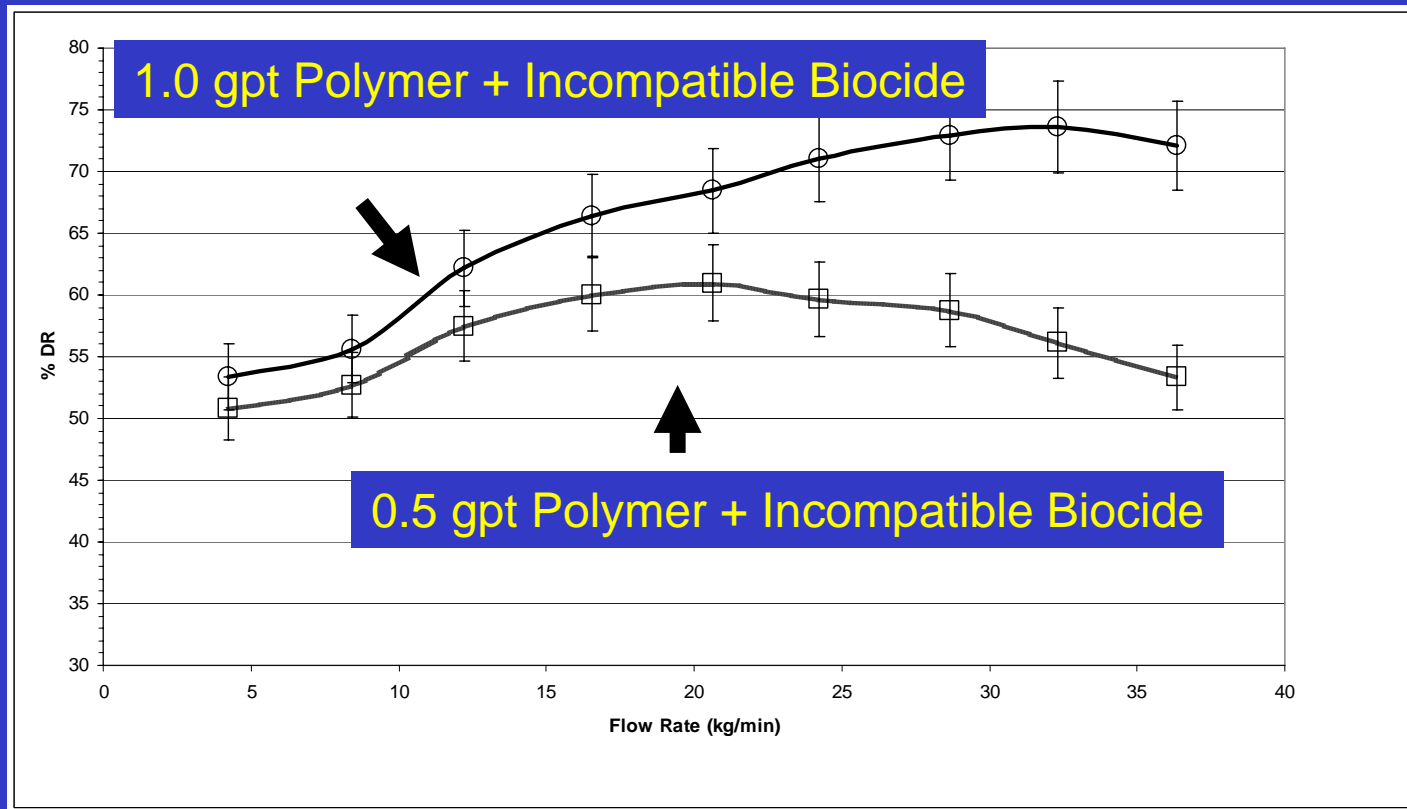

At higher polymer concentrations (0.5 – 1.0 gpt), the presence of the incompatible biocide results in moderate fluid performance

Field Example

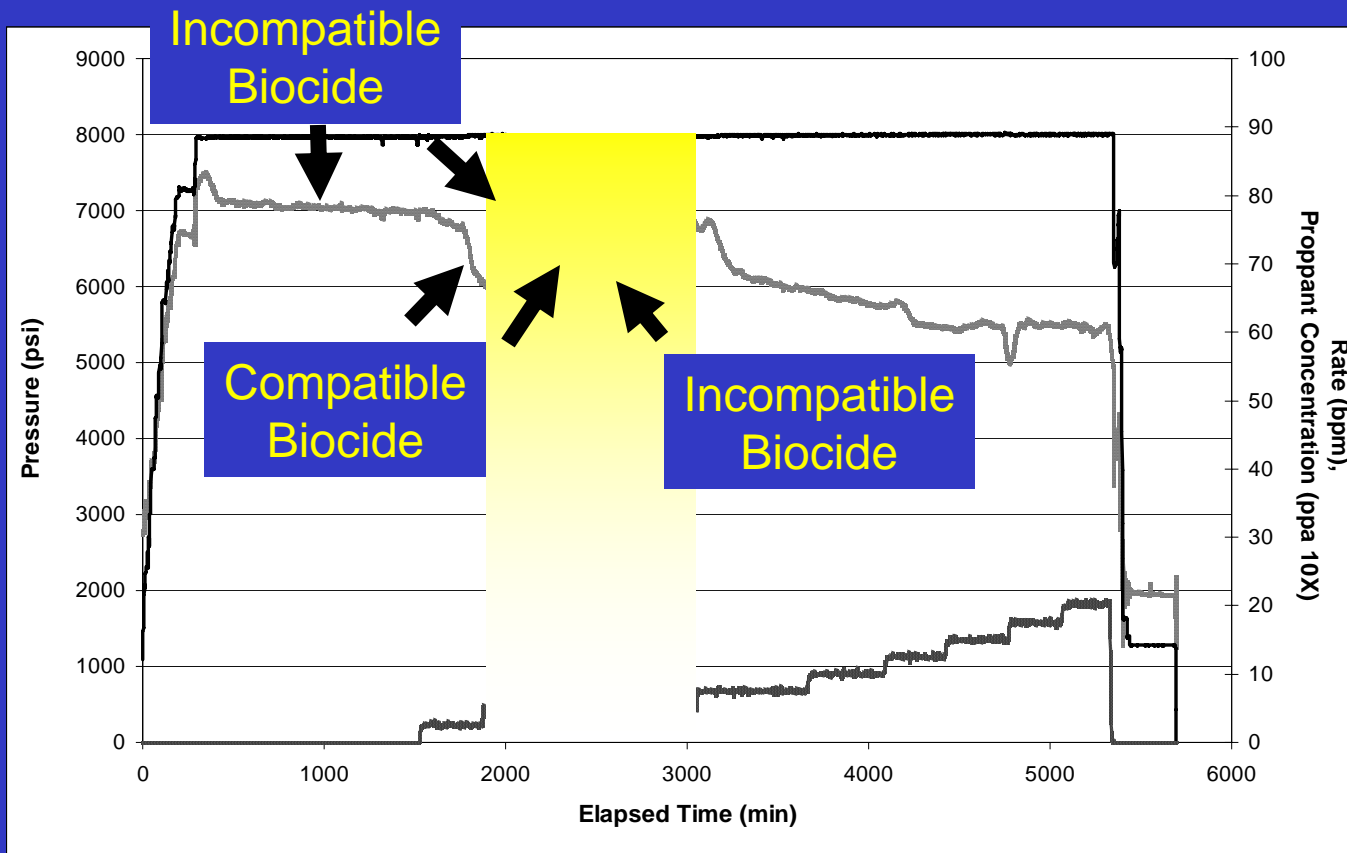

The presence of incompatible biocide increases treating pressures.

Optimized Fluid

Water Analysis

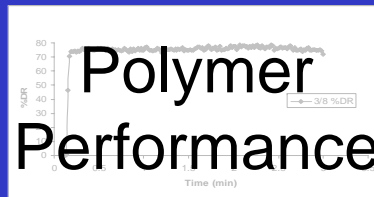
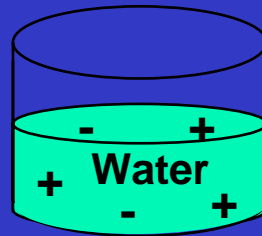

Scale	Concentration (mg/L)
FeO ₂	17185
CaSO ₄	721.165
SrSO ₄	191.16
BaSO ₄	168.020

Polymer Selection

Inhibitor Selection

Fri Biocide Selection

Optimized Fluid

Toxicity Tests on Aerobic Bacteria with a Friction Reducer, Biocide, and Scale Inhibitor

Plant Samples

Summary

- Friction reducer performance is affected by water quality
- Percent drag reduction does not increase significantly > 0.5 gpt
- Flocculation results when incompatible additives are mixed
- Use of incompatible biocides may reduce effectiveness of kill
- Optimize fluid performance to maximize well performance

⇒ ***Are you getting maximum value out of your fluid?***

Future Directions

- Need environmentally friendly additives
 - Solvent free friction reducers
 - Less toxic biocides but are still effective
- Higher salt tolerant polymers
 - Re-use of flowback waters

Questions?

- Thank you for your interest!!

Back Up Slides

Optimized Fluid

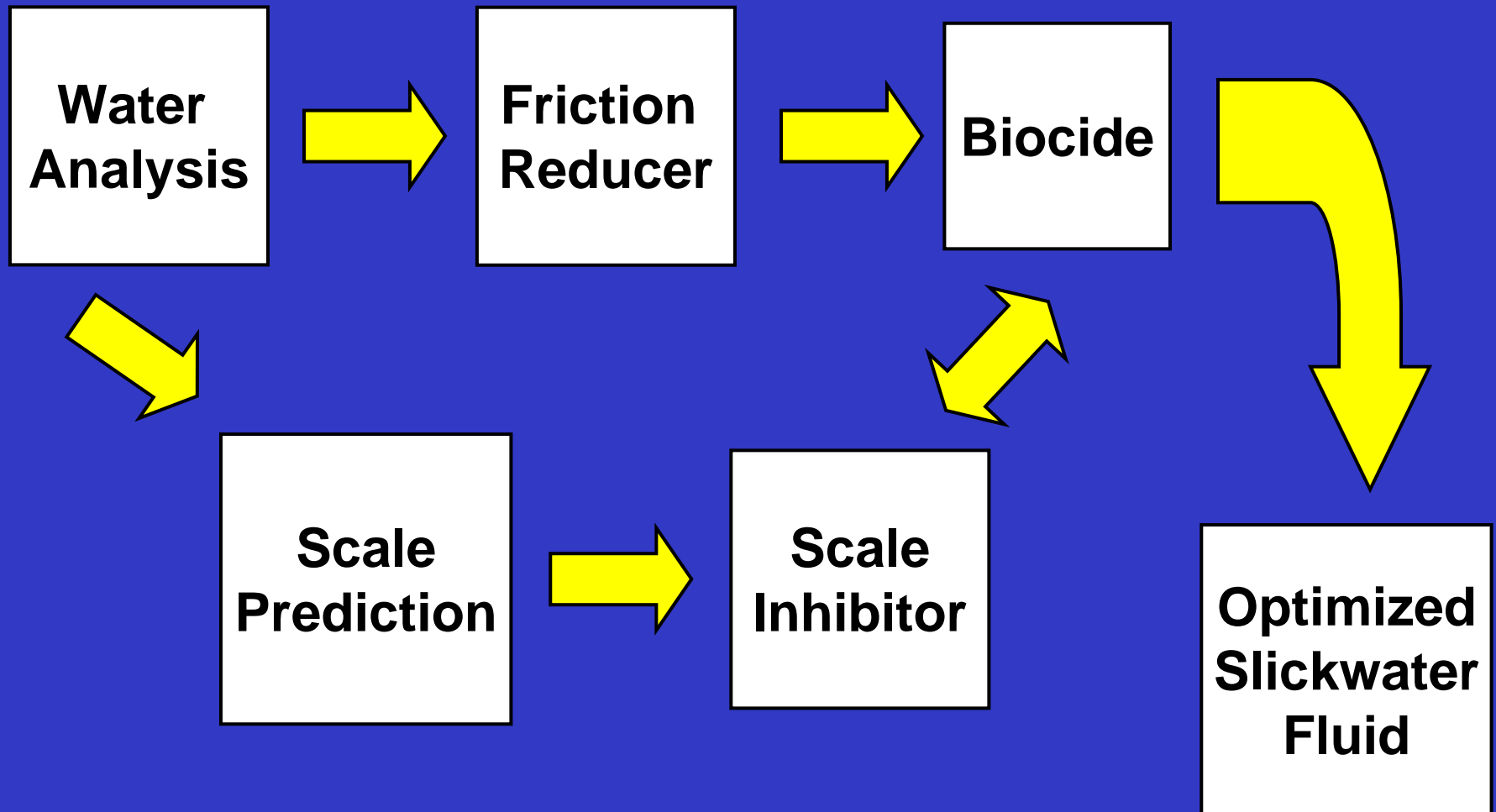

Example Data

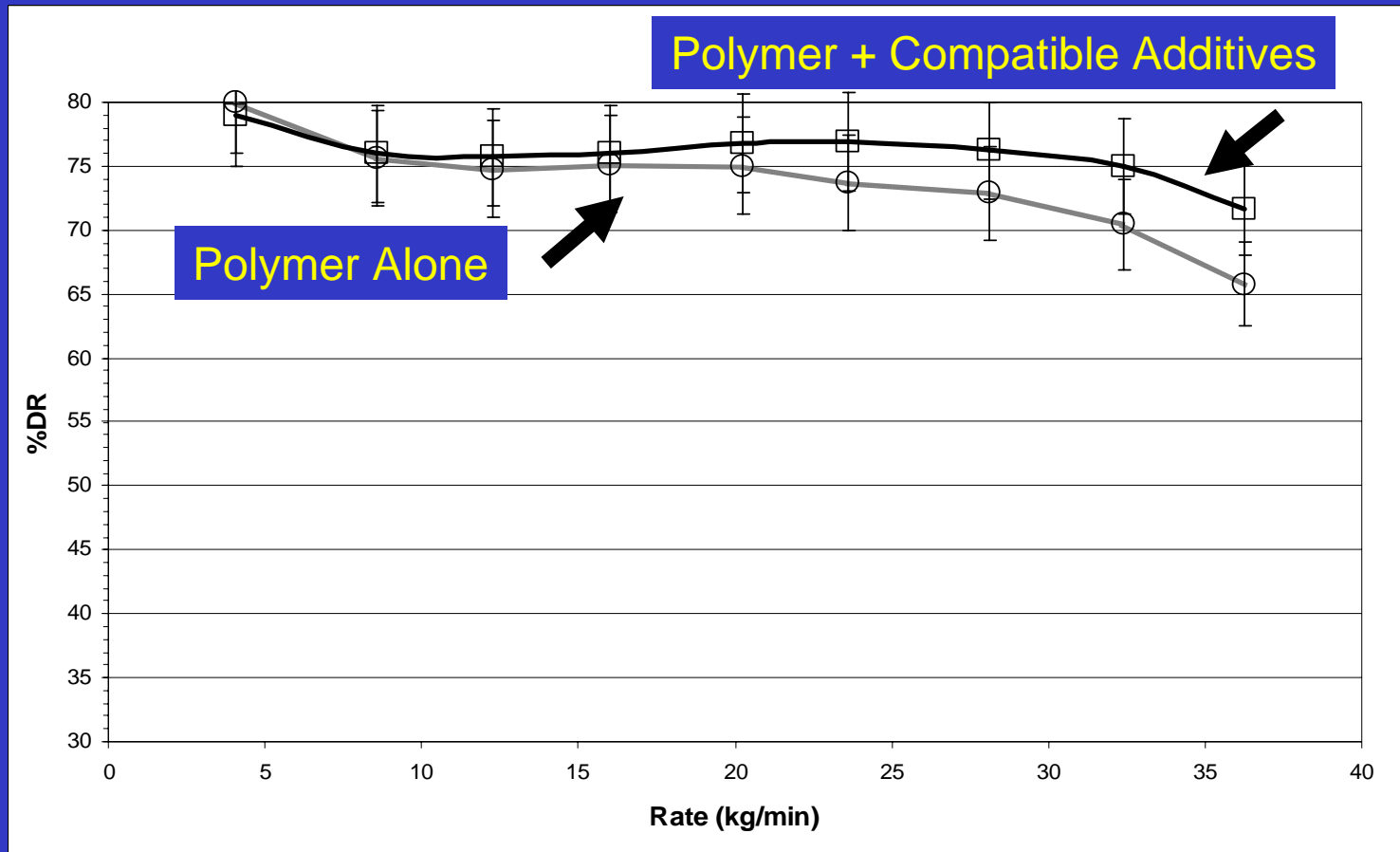

If all additives are compatible, fluid performance is not compromised.

Slickwater Chemistry

Water Chemistry

Ion Species	Ionic Composition Mg/l	
	Formation water	Seawater
Na ⁺	23215	11200
K ⁺	109	370
Ca ²⁺	702	400
Mg ²⁺	157	1400
Ba ²⁺	242	0
Sr ²⁺	180	6
Cl ⁻	41950	20000
SO ₄ ²⁻	0	2960
HCO ₃ ⁻	724	124

Drag Reducer Chemistry

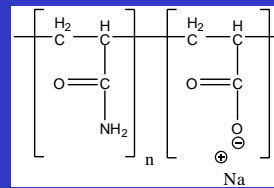

*Anionic
Polymers*

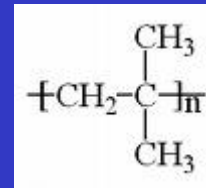

*Lipophilic
Surfactants*

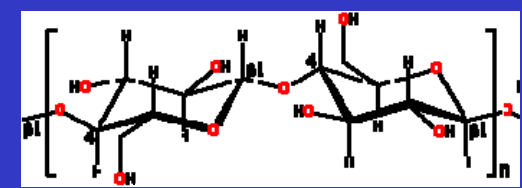

Biopolymers

Scale Inhibitor Chemistry

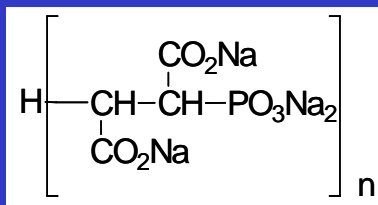

*Anionic
Co-polymers*

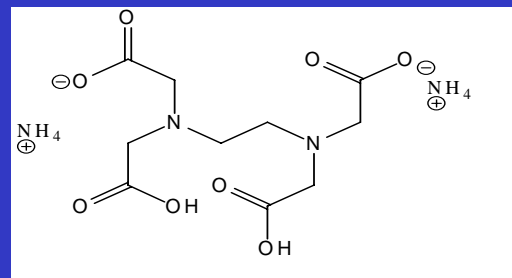

Amphoteric Buffer Molecules

Biocide Chemistry

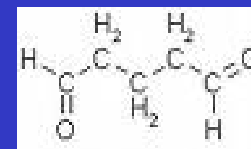

*Reactive
Aldehydes*

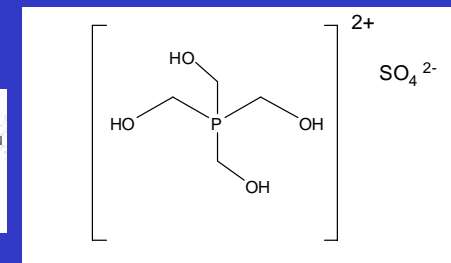

Reducing Agents