

**An Industry Lacking  
in Understanding  
Drilling Fluid Rheology.....**

**Dave Clark**

# The Challenge

---

- **Rheological instrumentation and practices currently being used in the oilfield have lagged other industries**
  - Limitations in terms of rheological characterizations
- **Rheological techniques can enable comprehensive rheological characterizations**
  - We must address their utility in satisfying the needs in technically challenging operations

# Viewpoint

---

- **Drilling fluid are better described as “weak solids” that easily deform and flow, than as “fluids”.**
  - Solid-like (elastic) behavior accounts for the ability of drilling muds to suspend solids and build gel structure.
- **Current oilfield rheological measurements do not address the solid-like behavior (elasticity) of drilling muds.**

# Rheology Take Away

---

- **What is the difference between a rheology and viscosity?**
- **What are a drilling fluid's rheological properties?**
  - We run tests to measure viscosity and gel strengths
    - Viscometers are used to measure rheological properties
  - We tend to improperly describe the fluid rheology
    - The rheological behavior cannot be described with only a viscometer
  - Equipment and techniques are available to improve fluid design

# Viscosity

---

- **Viscosity**
  - **Isaac Newton in 1687**
  - **Resistance to flow**
    - Viscous liquids such as water or oil.
    - Shear viscosity is constant with shear rate.
    - Viscosity independent of shear history and stress returns to zero immediately upon termination of shearing



# Elasticity

- **Robert Hooke (1660-1676)**
  - “True Theory of Elasticity”
  - **Elastic Solids**
    - Shear Stress is proportional to shear strain
      - Modulus of Rigidity

$$G = \frac{\tau}{\gamma}$$



Robert Hooke  
(1635-1703)

Robert Boyle, the Irish Physicist who defined of "Boyle's Law" wondered if a gas would act like the spring Hooke described !

# Viscoelasticity

---

- **Newtonian Behavior**
  - Ideal viscous (liquid) behavior
- **Hookean Behavior**
  - Ideal elastic (solid) behavior
- **Viscoelastic Behavior**
  - Material behavior that falls between the two classical extremes of purely Newtonian or Hookean
  - **Drilling fluids** exhibit viscoelastic behavior

# Rheology

---

## Rheology - Study of flow and deformation

- Aeronautics, hydraulics, fluid and solid mechanics
- Coined by Professor Eugene Bingham in 1920



# Viscoelasticity

---

- **Simultaneous existence of viscous (liquid-like) and elastic (solid-like) behavior in a material**
  - Viscous or elastic response depends on:
    - Material's natural time to deform
    - Time over which deformations are made
- **All viscoelastic materials exhibit non-Newtonian behavior**

# Rotational viscosity measurements

---

## Analyzed with empirical models

- **Models attempt to predict drilling fluids flow behavior**
  - Two parameter models
    - Bingham Plastic Developed during the evolution of clay based water-based mud
    - Power Law Does not describe the upper and lower regions of the viscosity
  
  - Three parameter models better describe the upper and lower regions of viscosity
    - Robertson-Stiff
    - Herschel-Bulkley

# Non-Newtonian Models

---

- **VG Meter rheology measurements alone can be misleading**
  - Provides limited amount of rheological information
    - Viscosity over a narrow range
  - Data can be misinterpreted by giving appearance of solids suspension behavior
    - As demonstrated with PAC vs. Xanthan Gum

# Liquid Behavior

---

- **Jumping off diving board versus off a rig**
  - Characteristic deformation time of water is the same in both cases
  - Rate of deformation different
- **Water exhibits both liquid and solid like behavior depending on the time of deformation**

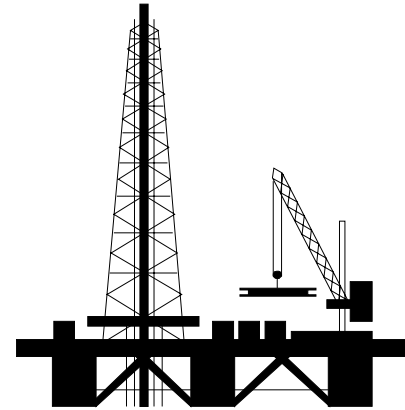

# Liquid Behavior

---

- **Silly Putty**

- Pull apart quickly
  - Solid-like behavior
  - Brittle failure
- Pull apart slowly
  - Liquid-like behavior
  - Ductile failure

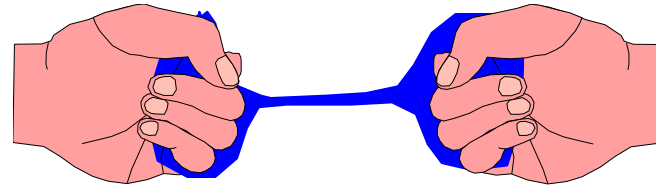
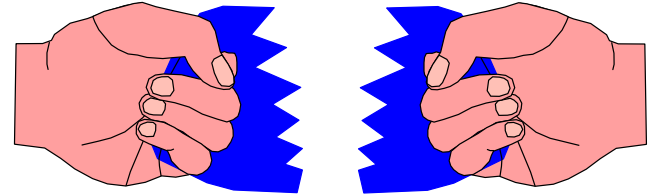

# Why the Need to evaluate our approach to drilling fluid rheology?

---

- **API mud rheology tests provide limited information**
  - Based upon steady-shear viscosity and gel strengths
  - Cannot reveal origin of structure or elasticity
    - Cannot delineate mechanism(s) of rheology modification

# Viscoelastic Moduli

- **Most common way of quantifying viscoelasticity is to measure moduli.**
  - $G'$  is elastic modulus
  - $G''$  is viscous modulus

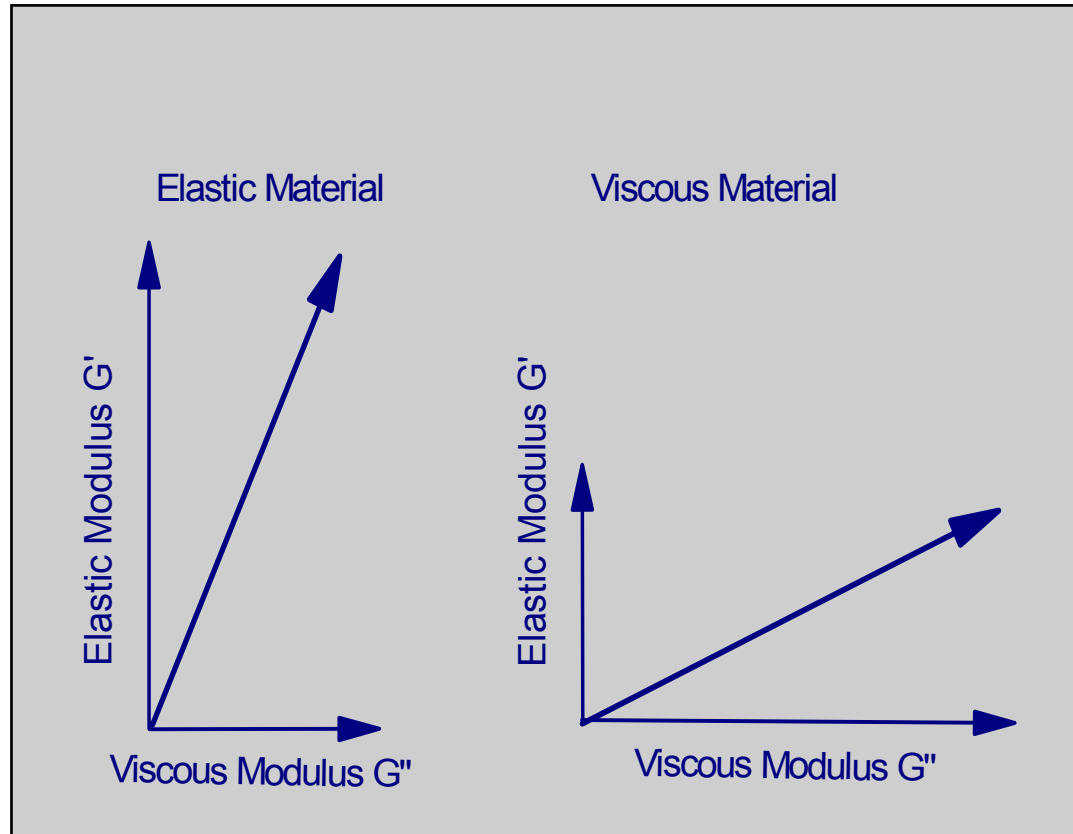

# Viscoelastic Moduli

- **Steady shear viscosity (VG Meter measurement) is a resultant vector of Elastic and Viscous moduli**
  - VG Meter viscosity are identical

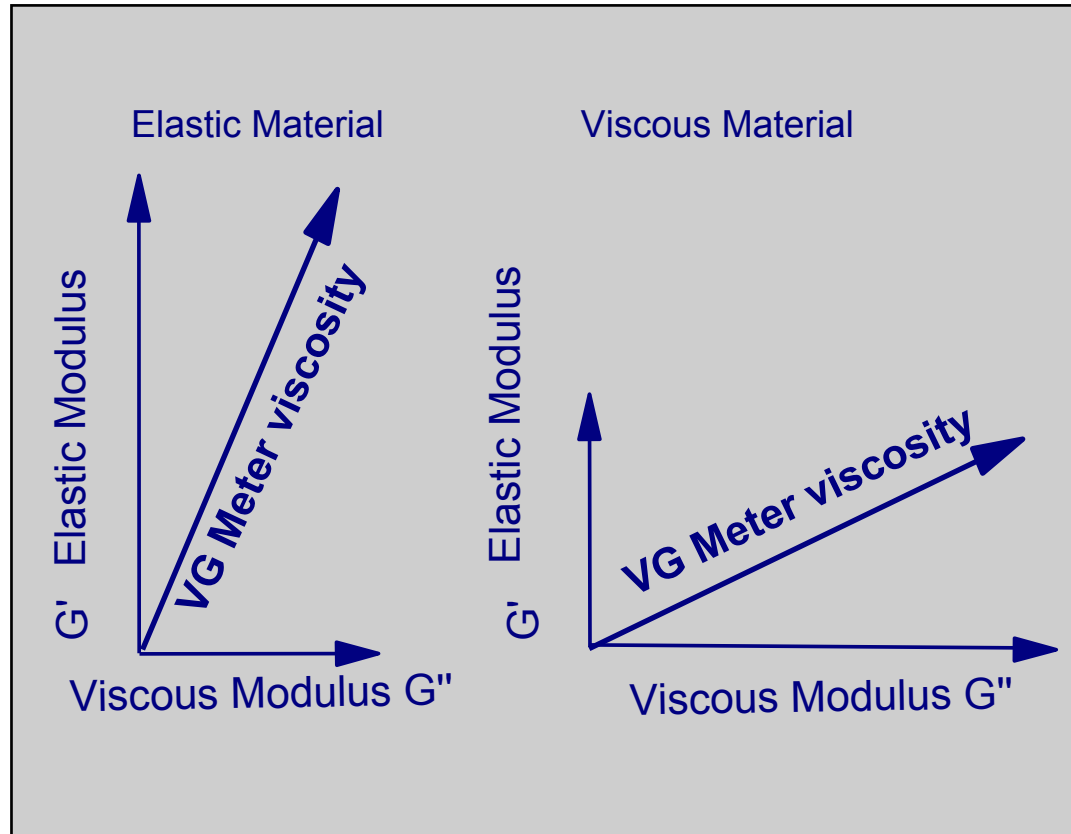

# Viscoelastic Moduli

- **Viscoelastic measurements would show that**
  - Viscosity more influenced by elastic modulus
    - Structured mud capable of suspending solids
  - Viscosity more influenced by viscous modulus
    - Poor solids suspension

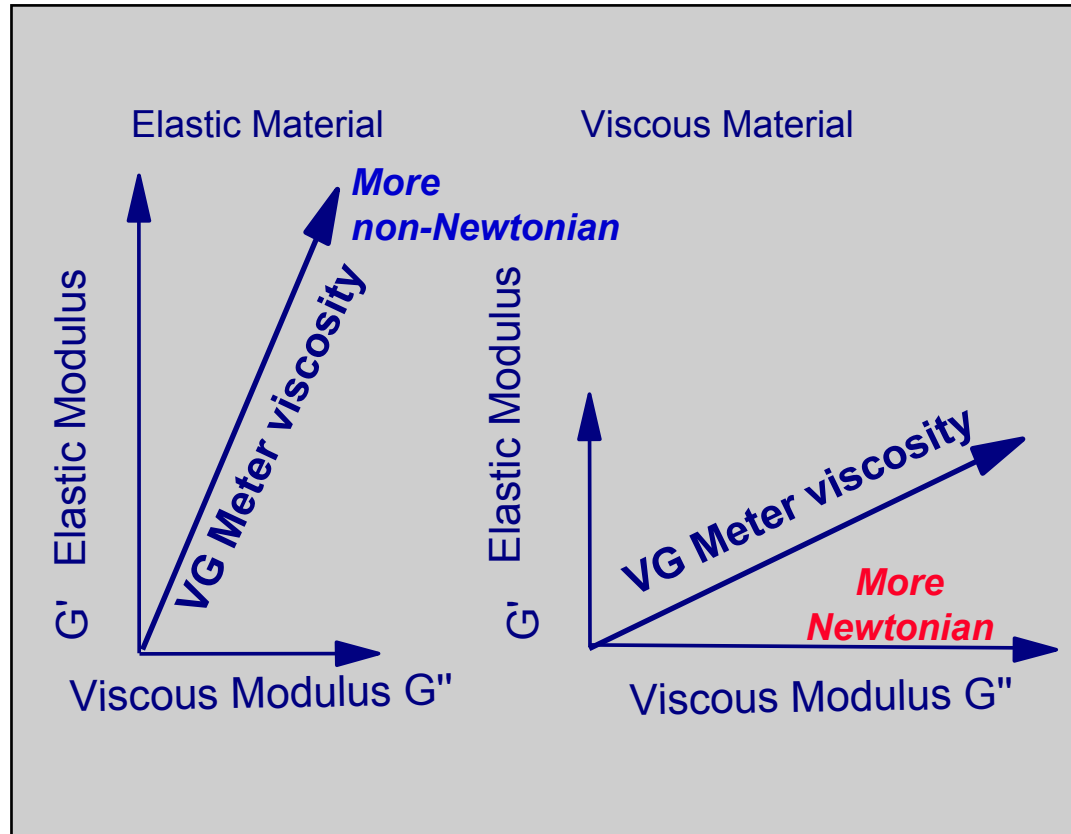

# It starts with Rheological Instrumentation

---

- **What is the difference between a viscometer and a rheometer?**
  - “.. the difference is that a viscometer can only measure viscosity whereas a rheometer can measure other rheological properties... it's all very casual. The rheometer/viscometer manufacturers may have different criteria that they use.” Dr. Faith Morrison

# Equipment and Rheology Evaluation



# Rheological Instrumentation

- **Viscometers**
  - **Funnel Viscometer**
  - **Oilfield Rotational Viscometers**
    - Fann Model 35
    - Fann Model 70 - 75
  - **Concentric Cylinder**
    - Measurements
      - Rotational viscosity in steady shear

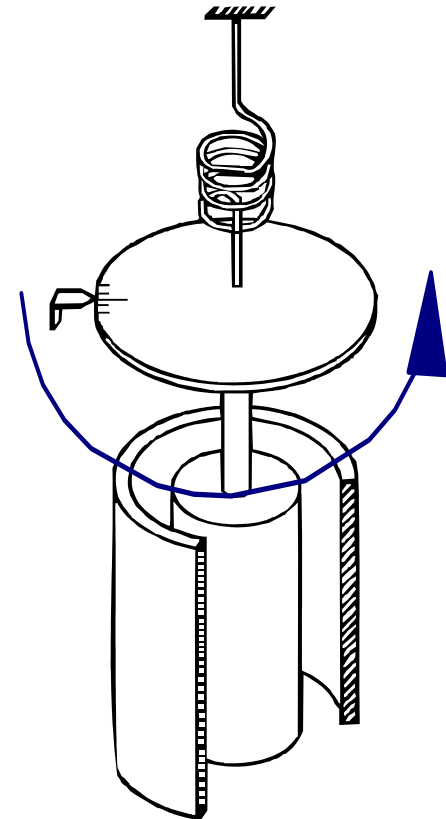

# Rheological Instrumentation (cont'd)

---

- **Rheometers**

- **Applications**

- Viscosity determinations
    - Viscoelastic determinations

- **Several geometries**

- **Measurements**

- Rotational
    - Oscillatory

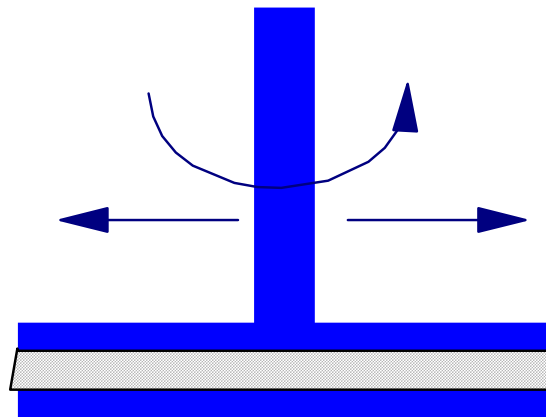

# Viscoelasticity of Drilling Muds

---

- Drilling muds generally exhibit non-Newtonian behavior
- Drilling mud rheology and structure arise from effects of viscosity and elasticity
- **Why do we rely on viscosity measurement alone?**

# Cox-Merz Rule - 1958

---

- **Rheological - Viscosity empirical rule:**
  - In fluids that do not exhibit a 3-D, linked network
    - Rotational viscosity ( $\eta$ ) will be equivalent to oscillatory viscosity ( $\eta^*$ )
  - Complex viscosity = Rotational viscosity + structure

# Cox-Merz Rule

- Compare rotational viscosity  $\eta$  (eta) to complex viscosity  $\eta^*$  (eta\*)
  - Confirms that viscosity arises from non-specific interactions
    - Polymer entanglement
    - No elasticity at low frequencies and shear rates
    - 3-D, linked network does not exist

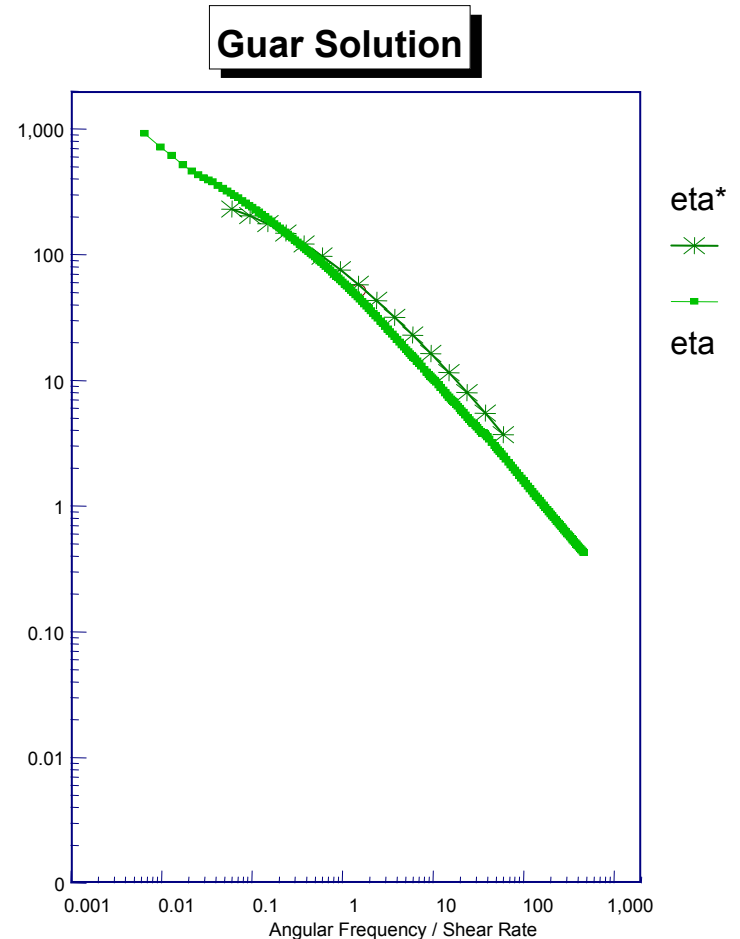

# Cox-Merz Rule

## $\eta$ and $\eta^*$ do not superimpose

- **Complex viscosity higher than rotational viscosity**
  - 3-D, linked network exists
  - $\eta^* - \eta = \text{Contribution of Elasticity}$

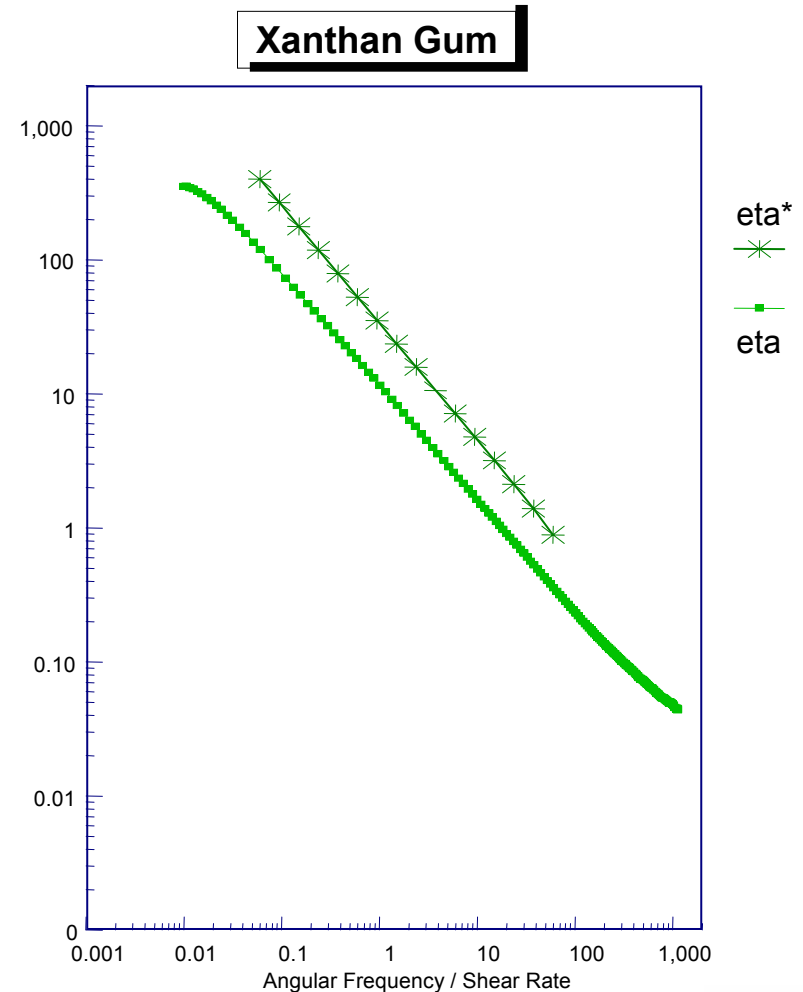

# Elasticity

---

- Why are “elasticity” measurements critical?

# Xanthan Gum

- **12.5 lb/gal fluid**
  - 2 lb/bbl Xanthan
  - **VG Meter rheology measurement**
  - Properties @ 77° F
  - 150° F Hot roll
    - 6 rpm = 25
    - 3 rpm = 23
    - PV = 13
    - YP = 39

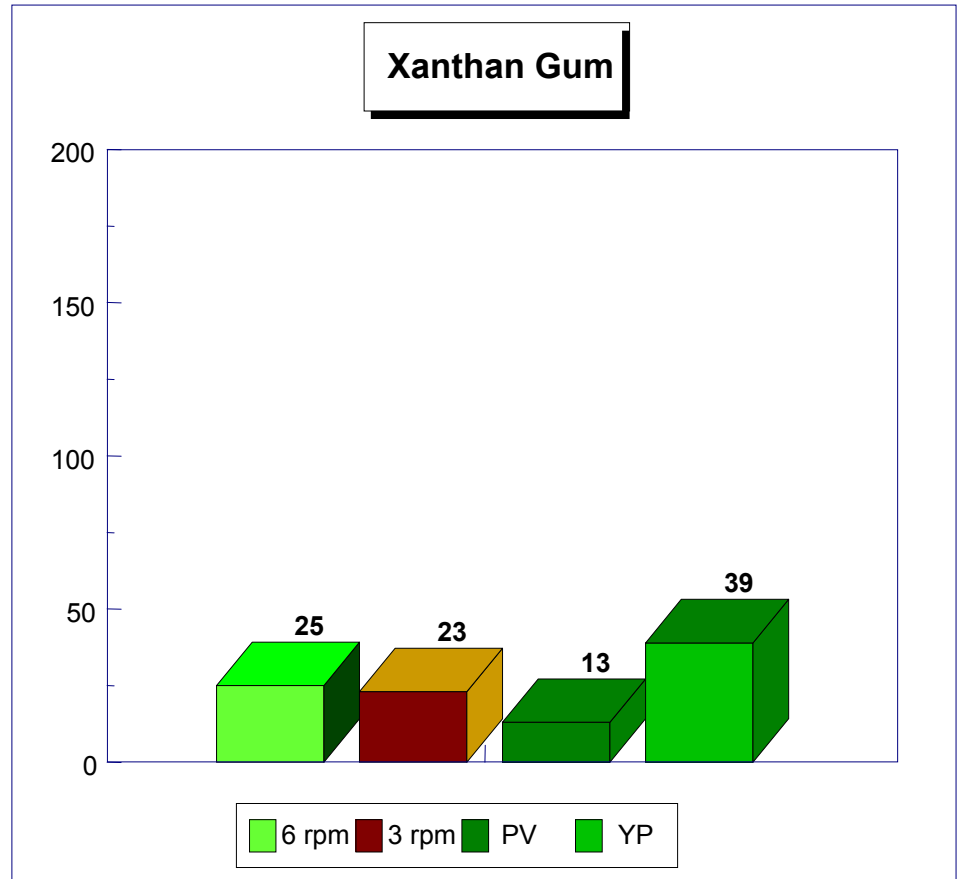

# Xanthan Gum

- **Flow Curve test - Viscosity**

- Networks are broken in process of performing the test
- Sample is shear thinning
- No obvious lower or upper Newtonian regions

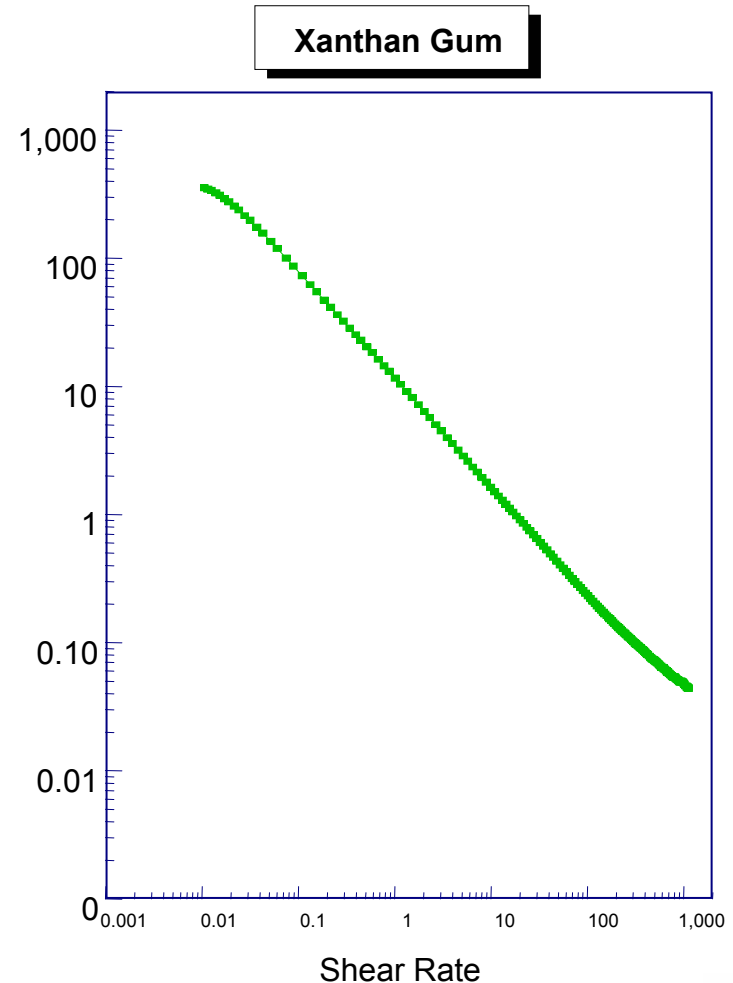

# Xanthan Gum

- **Dynamic Frequency Sweep**
  - **Elastic behavior**
    - Elastic modulus dominates over entire frequency region
    - Viscoelastic moduli decrease with decreasing frequency
    - $\eta^*$  increases with decreasing frequency

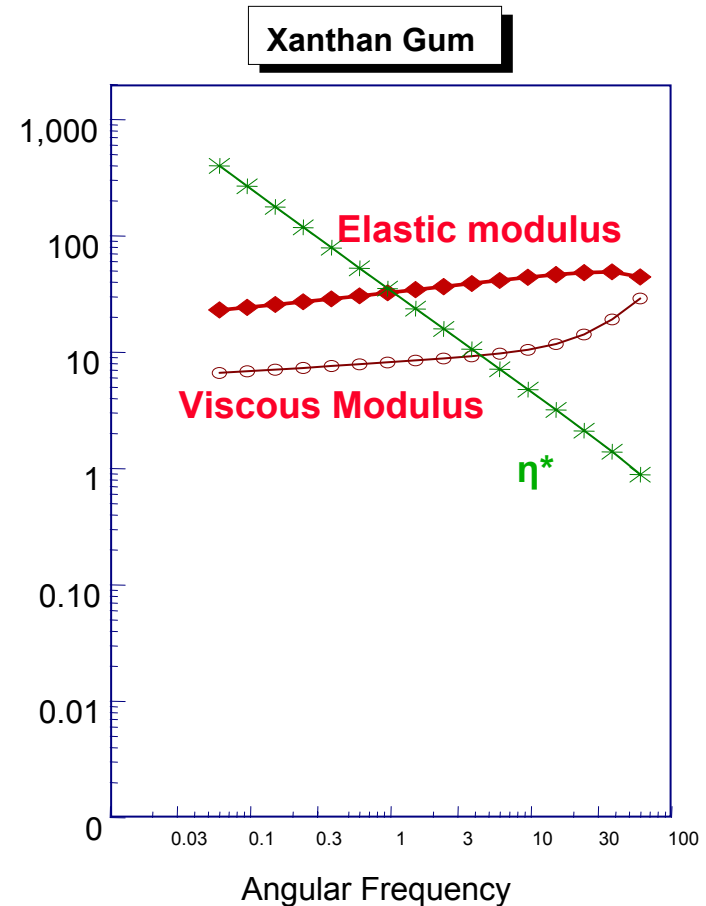

# Xanthan Gum

- **Superimpose flow curve over frequency sweep**
  - Confirms specific particle interactions
  - Separation of  $\eta$  and  $\eta^*$
  - This mud has potential to suspend solids
  - Elastic behavior at low deformation rates
    - Shear rates
    - Angular frequency

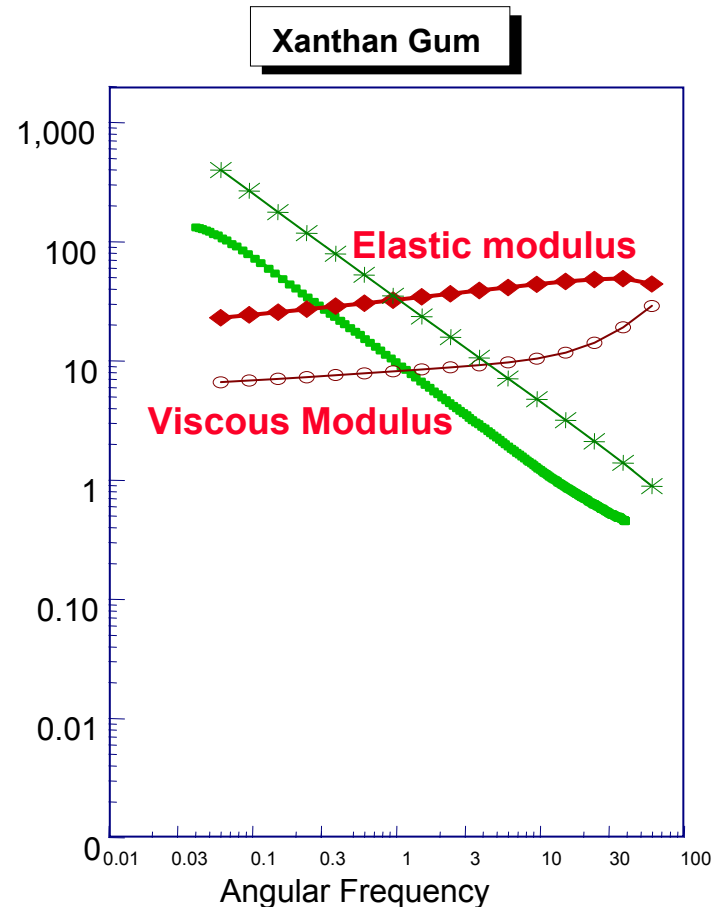

# PAC Regular

- **12.5 ppg fluid**
  - 2 ppb PAC R
- **VG Meter rheology measurements**
  - Properties @ 77° F
  - 150° F Hot roll
    - 6 rpm = 14
    - 3 rpm = 8
    - PV = 13
    - YP = 133

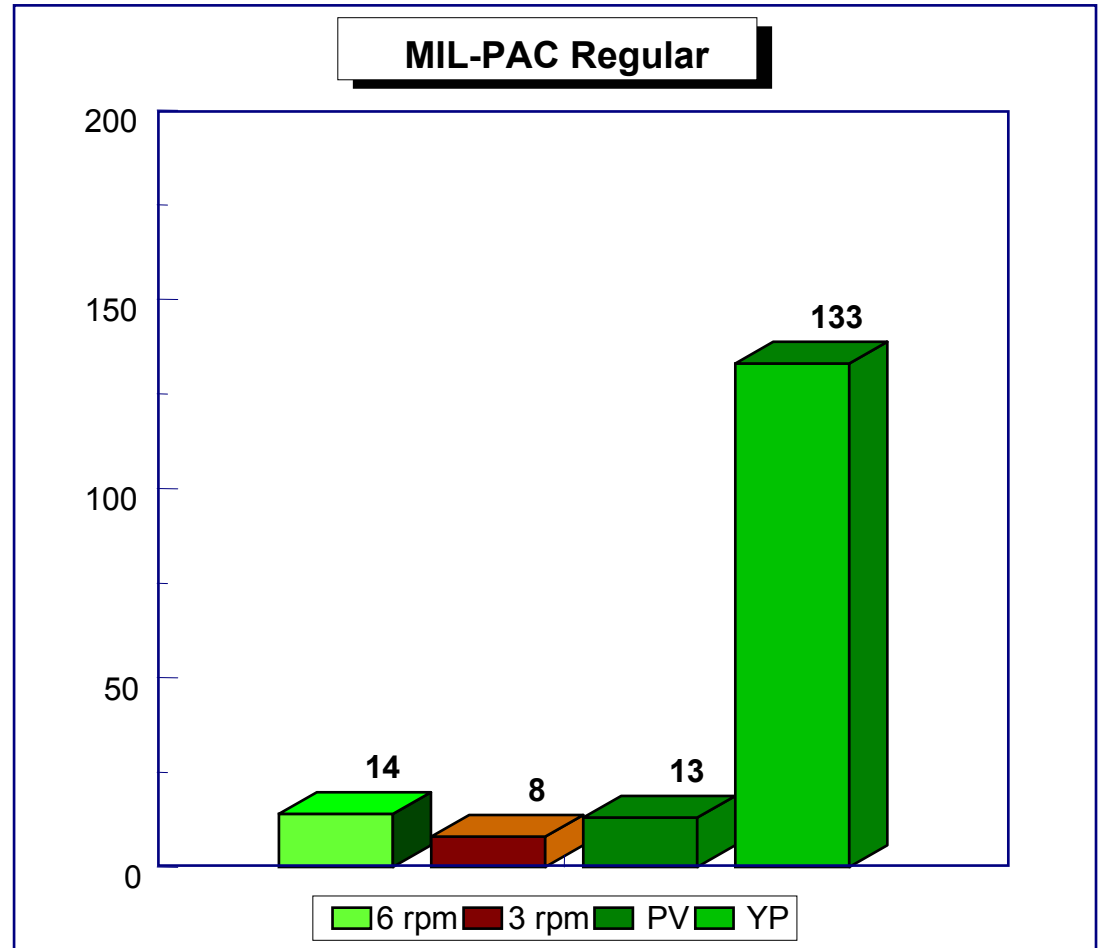

# PAC Regular

- **Flow Curve test**

- Sample is shear thinning
- Lower Newtonian region
  - Indicator that there is a problem

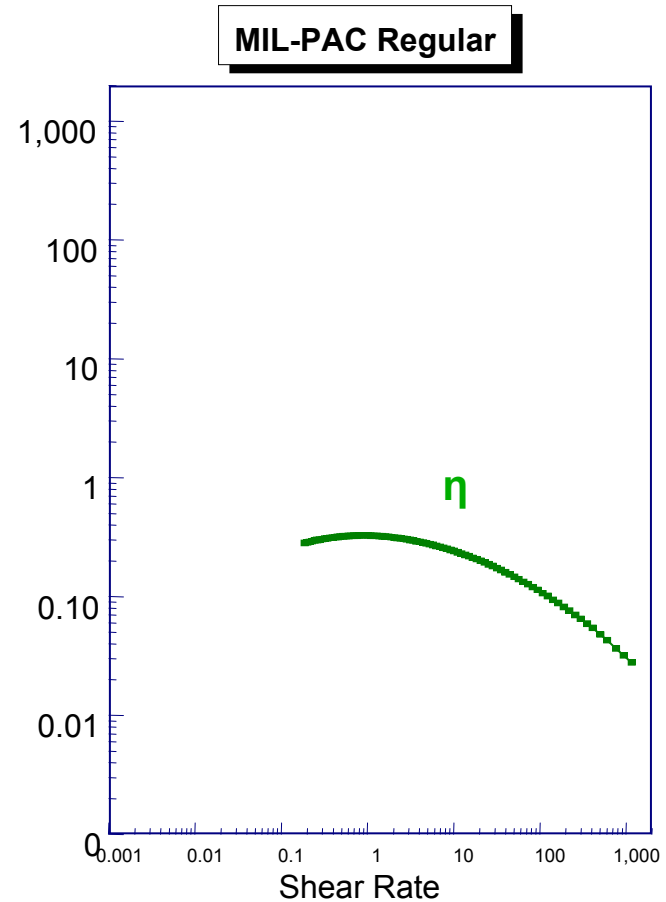

# PAC Regular

- **Dynamic Frequency Sweep**
  - **Viscous behavior**
    - Viscous modulus dominates over entire frequency region
    - $\eta^*$  and decrease with decreasing frequency
    - Newtonian characteristics

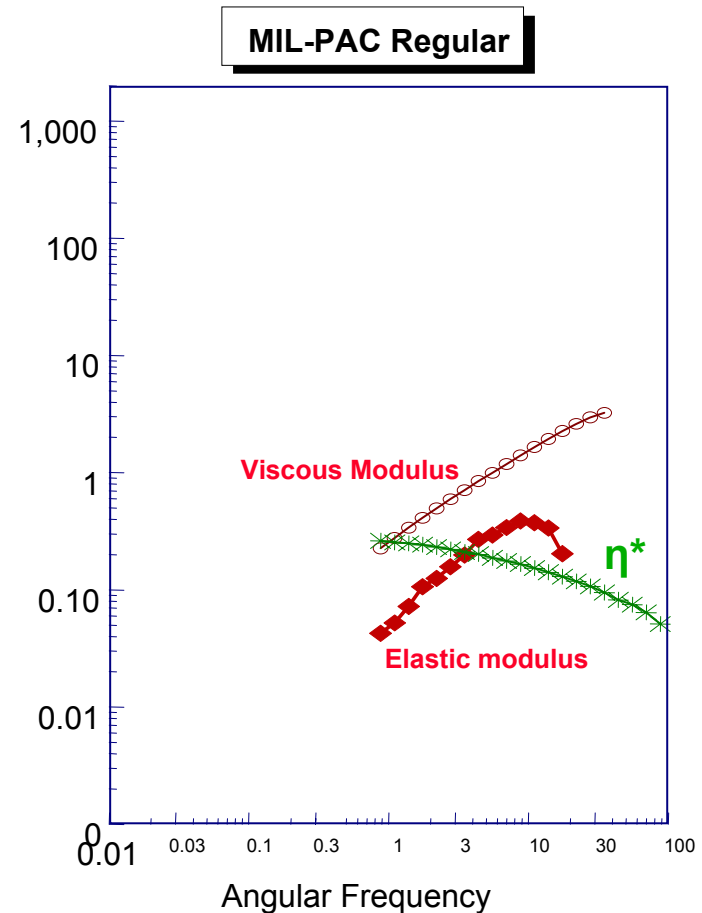

# PAC Regular

- **Superimpose flow curve over frequency sweep**
  - Confirms non-specific particle interactions
  - Lower Newtonian region
  - This mud will not suspend solids

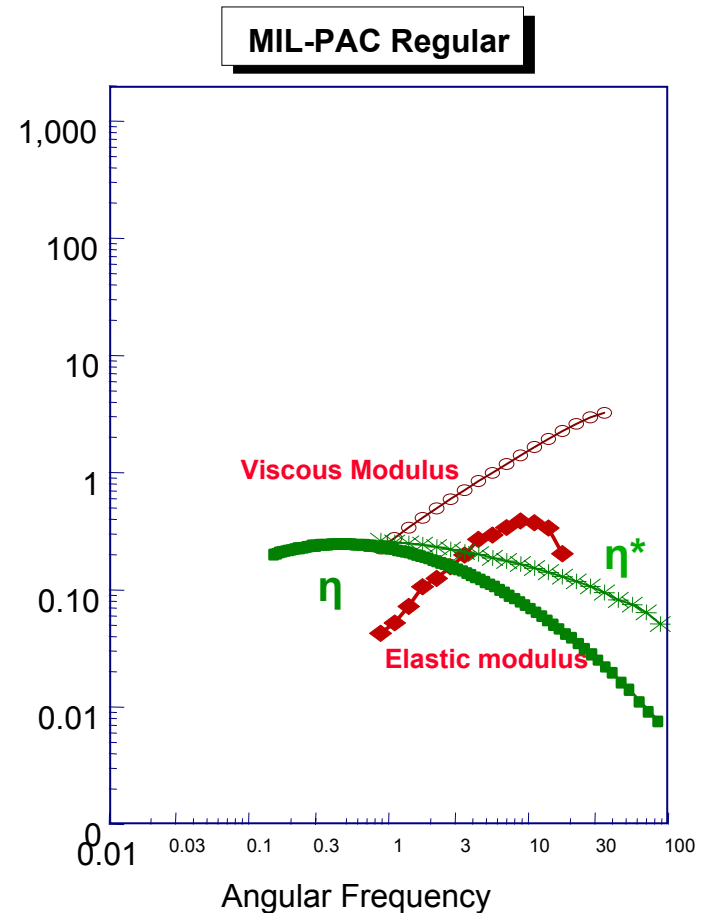

# Synthetic-Based Fluids

## Effect of components

### ● Addition of Organophilic Clay

- 10-fold increase in elastic modulus
- Greater separation of viscoelastic moduli
- Elastic modulus less frequency dependent
  - Stronger gel

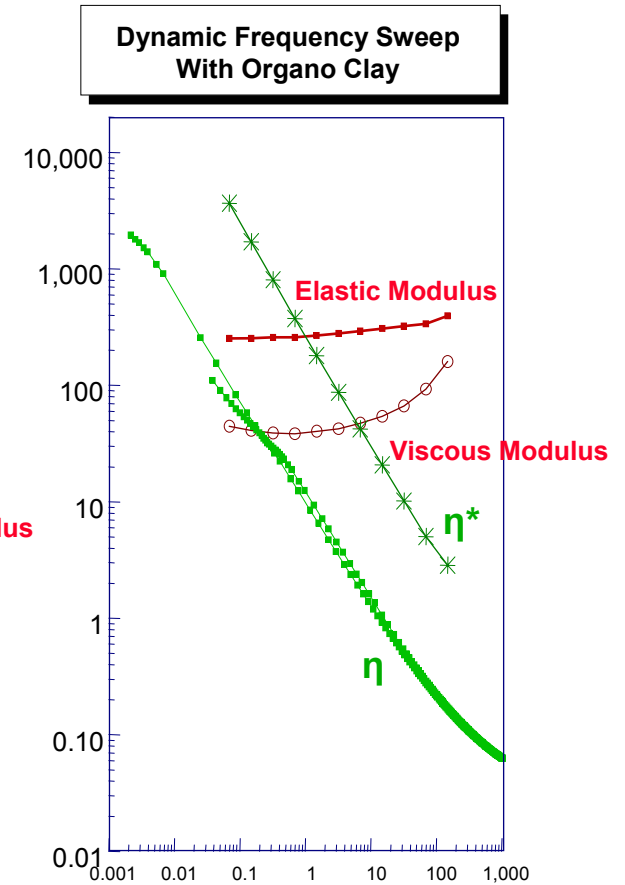
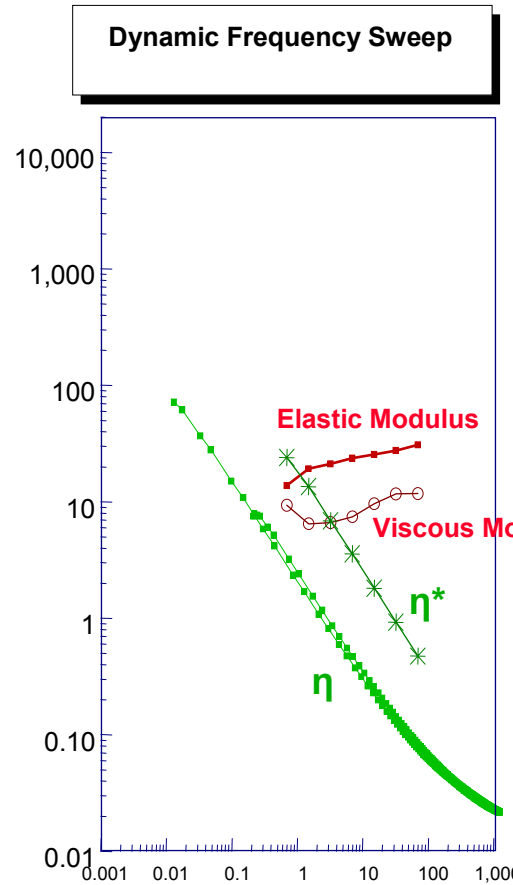

Angular Frequency, rads/sec & Shear Rate, s<sup>-1</sup>

# Effects of Components

- **0.5 gal/bbl wetting agent**

- Collapse of structure
- Magnitude of moduli decrease

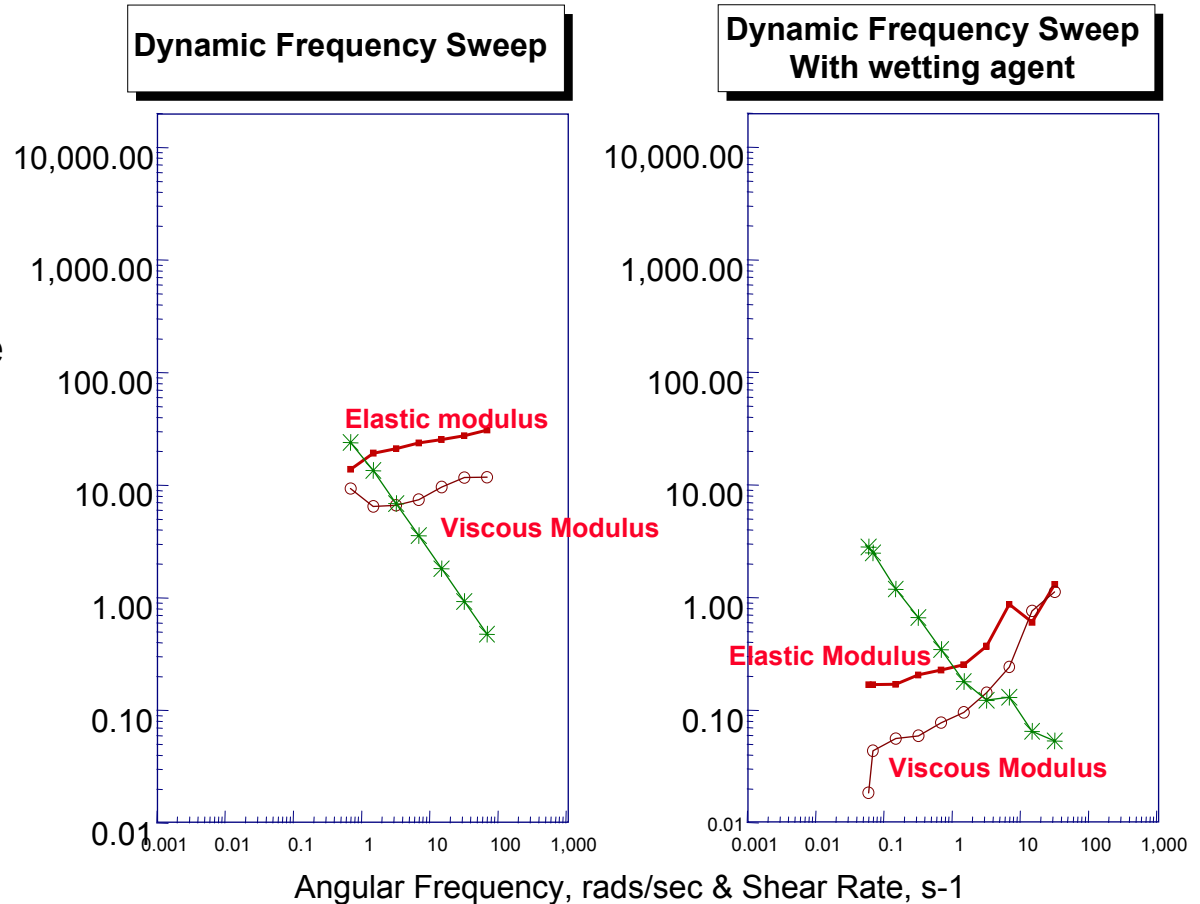

# AADE Test

---

- **Winners to receive**
  - **Free admission to the next Fluids Management Group Meeting**

# API Rheology – Which is more prone to Barite Sag?

**Field Mud A**  
14.0 lb/gal, 80/20 SWR

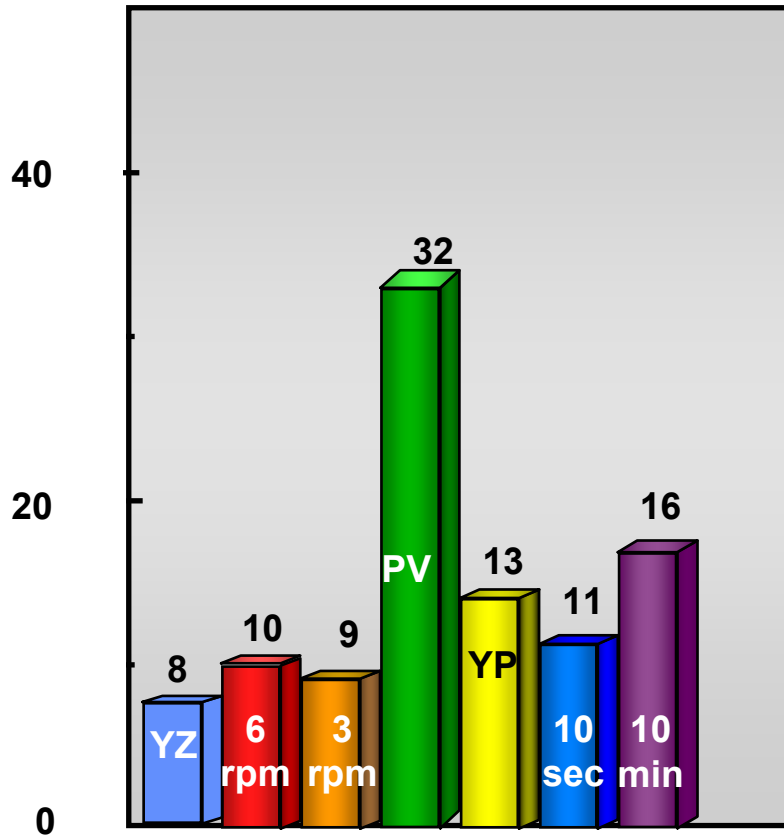

**Field Mud C**  
13.5 lb/gal, 80/20 SWR

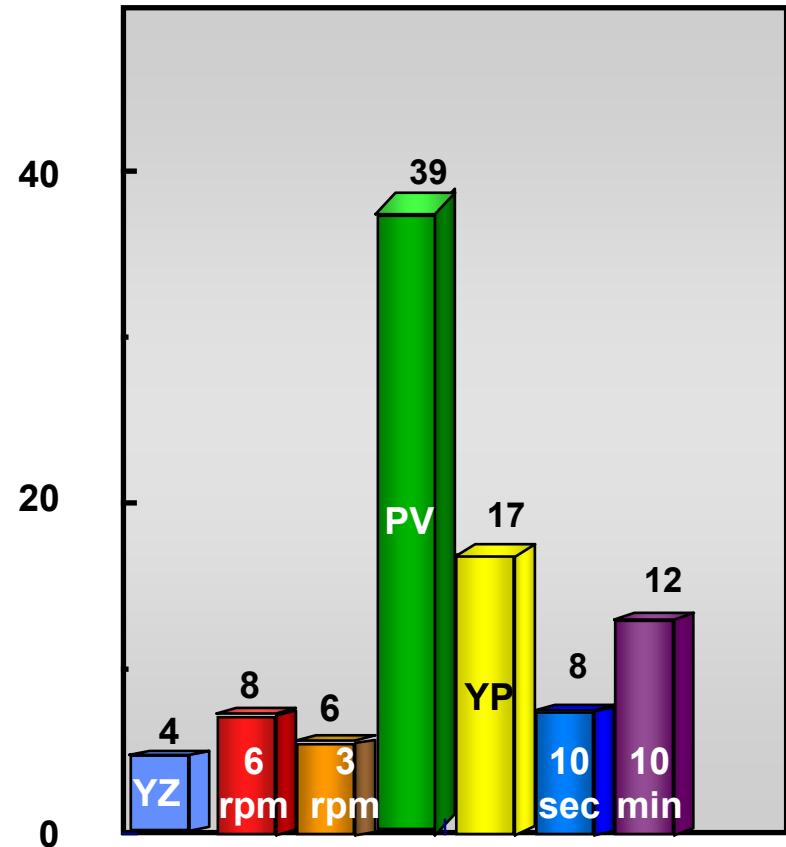

# Dynamic Frequency Sweep Which is more prone to Barite Sag?

**Field Mud A**  
14.0 lb/gal, 80/20 SWR

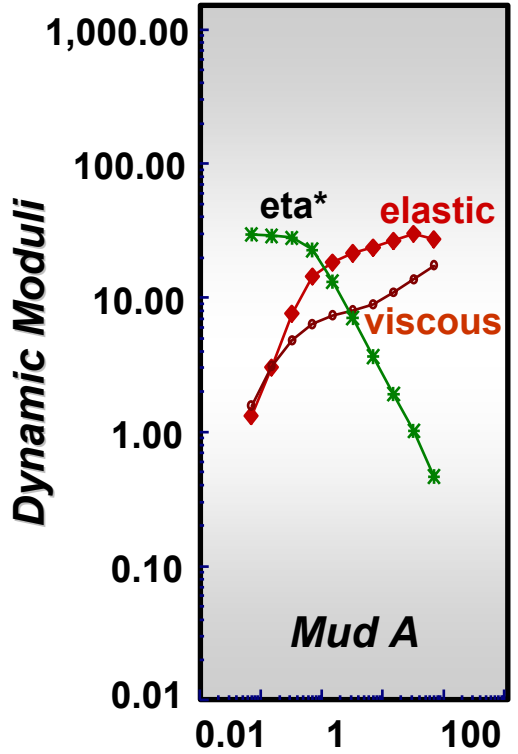

**Field Mud C**  
13.5 lb/gal, 80/20 SWR

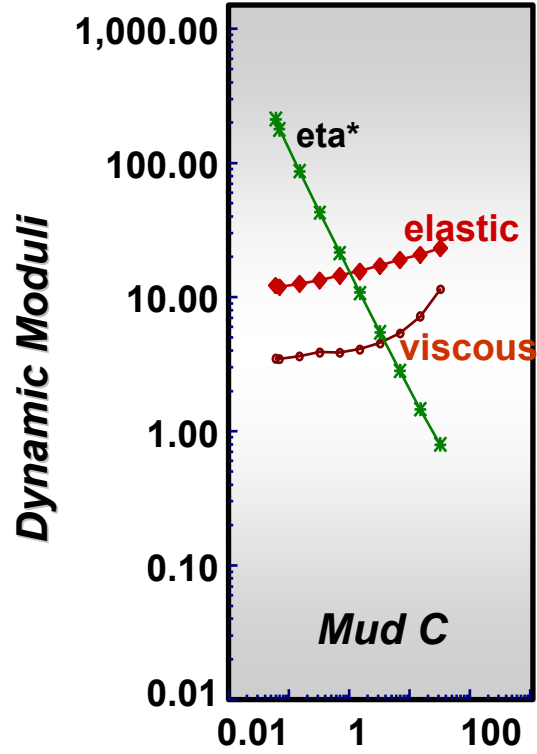

© 2004 Baker Hughes Incorporated  
All rights reserved.

# Which is more prone to Barite Sag?

- Field Mud A
  - Sag problems
- Field Mud B
  - No barite sag

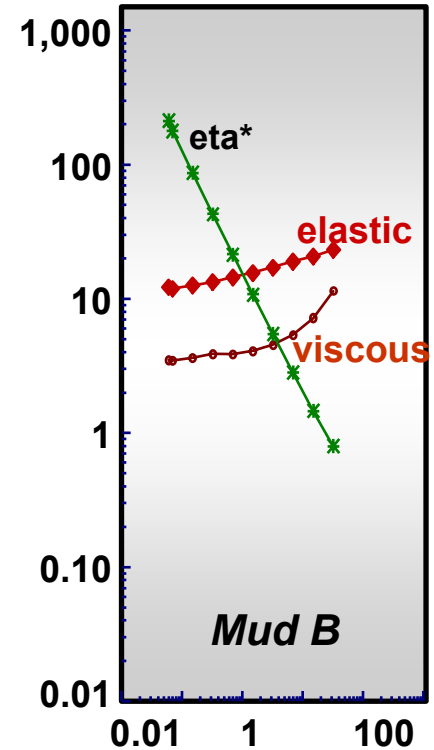
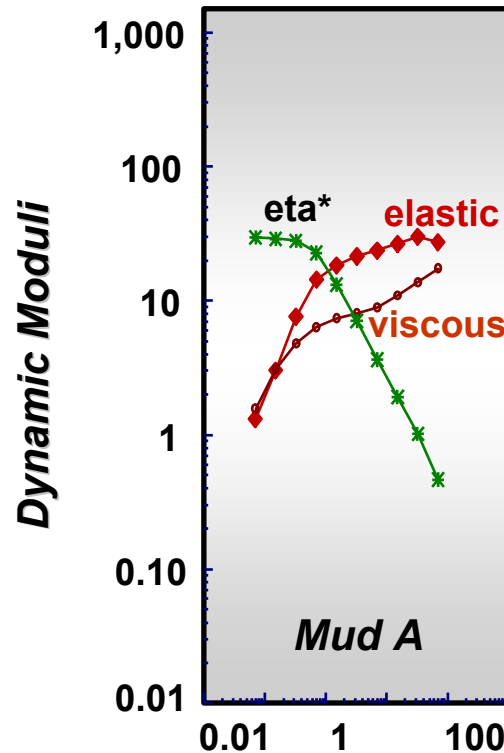

# Which is more prone to Barite Sag?

- **Field Mud A**
  - Sag problems
- **Field Mud C**
  - 16.5 lb/gal
  - 80/20 SWR
  - No sag problems

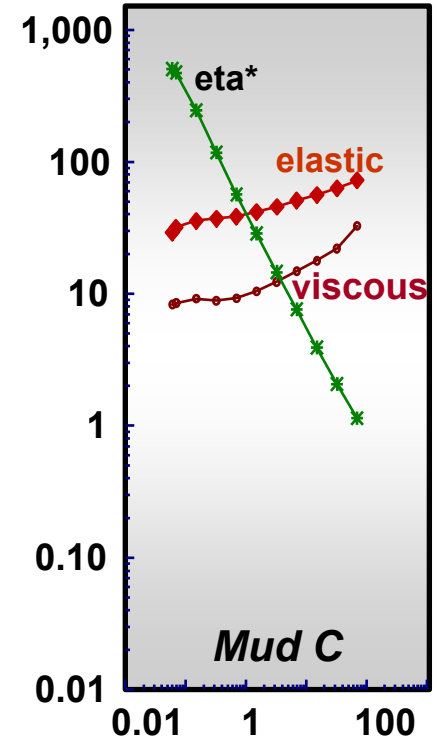
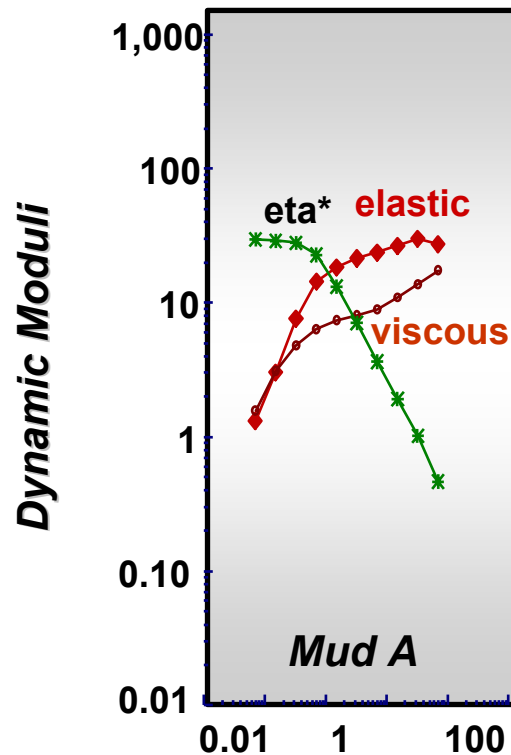

# Conclusions

---

- **We must move away from using viscosity alone to describe drilling fluid rheology**
- **Drilling Fluids with similar API rheological properties can exhibit different field performance**
  - Drilling mud rheology arises from contribution of elasticity
    - Traditional rheological techniques do not address the elastic behavior of drilling muds
- **Viscoelastic techniques can be used to differentiate between these fluids**
  - Cannot quantify viscoelasticity using API rheological techniques
  - Viscoelastic techniques are straightforward and quantitative
  - Complete rheological characterization of the drilling fluid



---

## Drilling Fluids

**Thank you**

**Dave Clark**