

A Rocky Mountain Expandable Liner Hanger Completion: Case History Success Story

Michael Tunstall and Kristina Loop, Halliburton Energy Services, Inc.; and Dominic Spencer, Bill Barrett Corporation

Copyright 2007, AADE

This paper was prepared for presentation at the 2007 AADE National Technical Conference and Exhibition held at the Wyndam Greenspoint Hotel, Houston, Texas, April 10-12, 2007. This conference was sponsored by the American Association of Drilling Engineers. The information presented in this paper does not reflect any position, claim or endorsement made or implied by the American Association of Drilling Engineers, their officers or members. Questions concerning the content of this paper should be directed to the individuals listed as author(s) of this work.

Abstract

When drilling and completing deep sandstone wells in Rocky Mountain basins, there are specific challenges concerning hydraulic fracturing and production string configurations that must be addressed in order to prevent well loading during production.

These wells require hydraulic fracturing in order to be productive. This process can create additional challenges if the wells are completed with a liner, and the stimulation treatment is pumped down the intermediate casing. Therefore, designing the drilling program with consideration for the final completion is critical for attaining optimal cost and operational efficiency.

This paper discusses development of a deep, tight-gas high-pressure well in a field outside of Casper, WY. Since the target zone in this well was deeper than in most of the other wells in that area, it was felt that the completion and stimulation methods traditionally used would require modification for this completion. All available options were reviewed, and an expandable liner hanger was chosen for the completion. In this instance, a significant length of polished bore receptacle (PBR) was strategically set below the liner hanger, and the well was completed with a work/production string that stung into the PBR. This allowed for the substantial tubing movement that was anticipated during the stimulation treatment. This also enabled the work string to be used ultimately as a production string.

Benefits included the following:

- By using the expandable technology, financial and operational advantages over conventional liner hanger system were generated.
- Cost comparisons to alternative well completion scenarios with production casing run to surface showed substantial cost savings for this completion method.

Introduction

The subject well is located in the Cave Gulch Field in Natrona County, Wyoming. Primary target formation was the Muddy Sandstone. Permeability estimates are between 1 to 2 md (matrix permeability), and bottomhole temperatures are approximately 315° F. Reservoir characteristics are described in depth by LeGrand, Parrott, and Enterline.¹ As is

the case with the majority of wells in the Rocky Mountain basins, this well would require hydraulic fracturing.

Therefore, a specialized completion system that would accommodate the challenges of pumping a gelled stimulation treatment and offer plug-back options would have to be developed. In addition, because of logistics and cost, the greatest economic benefit to the completion scenario would be generated if the work string could be used as the permanent completion string.

Wellbore Design Considerations

As previously mentioned, the final well completion would have to be designed around the stimulation treatment for a number of reasons. The first issue concerned the fact that the target zone was a sandstone reservoir at approximately 19,000 feet. The second consideration was that it might be necessary to test, stimulate, and explore other production zones even deeper than the target reservoir.

When designing casing strings for this well, an intermediate string would have to be set. In an ideal situation, the production casing would have been to run to surface. However, that was not possible in this scenario because of the depth targeted. In traditional Rocky Mountain tight-gas, high-pressure wells, the production casing is run to surface, and the stimulation treatments are simply pumped down the casing, setting composite plugs in between highly layered lenticular sands.² However, most of these wells, although deep, have not been quite as deep as this particular well.

The subject well also differed in that it had only one major target zone. A 5½-in. production liner was chosen to be set at 15,780 ft in the 9-7/8-in. intermediate casing string. When reviewing the well parameters, several cost constraints were noted:

1. Running this production casing to surface would have been extremely uneconomical when considering the cost of steel and cost of the rig time to run the pipe
2. Running the production casing to surface at that depth might also exceed the casing tension limits.

The option of running the production casing to surface was, therefore, eliminated from consideration.

Another option was to use a work string with a tie-back seal assembly in order to accommodate the target zone

stimulation treatment at 19,000+ feet. Choosing this option would not only present a cost concern, but logistics such as lead time and availability of the casing would also have to be considered in the stimulation design.

Stimulation Challenges

Pumping large volumes of sand-laden gel down the 9-7/8-in. intermediate casing string posed several risks: First, the wellhead treating pressure would have been nearly 100% of the burst pressure of the casing while pumping the stimulation treatment down the intermediate casing string. This surface treating pressure value was estimated by using the following equation to calculate the expected treating pressure

$$P_{\text{wellhead}} = \text{BHTP} - P(\text{hydrostatic}) + P(\text{perf friction}) + P(\text{pipe friction}) \dots \dots \dots (1)$$

The burst rating of the 9-7/8-in. casing was 13,840 psi.

The calculated treating pressure (using anticipated rate and expected frac gradient of 1.05psi/ft) was estimated to approach 12,500 psi using the following assumptions:

- P(hydrostatic) = approximately 8383psi.
- P(perf friction) = approximately 700psi
- P(pipe friction) = approximately 200psi.

This surface wellhead treating pressure would have exceeded safety factors and posed a safety hazard. This potential hazard substantiated the need for a tubing string.

The burst pressure of 3½-in. tubing is 20,630 psi. Pumping down the 3½-in. tubing would have higher friction pressures than pumping down the 9-7/8-in. casing because the inner diameter is much smaller. The pipe friction pressure in this case was estimated to be approximately 3500 psi. Using the same formula to figure the fracture gradient, a treating pressure of just under 16000 psi would be expected, if the treatment was to be pumped down the tubing.

Although the absolute value of the treating pressure is higher pumping down tubing, using this option is safer as 16000 psi would be approximately 78% of the burst pressure of 20,630 psi as opposed to over 90% of the burst pressure in the first scenario.

Secondly, if a screen-out during the job should be indicated at surface (while pumping down the 9-7/8-in. intermediate string), it would be almost impossible to address as job adjustments would take too long to take effect.

Comparing wellbore volumes with and without a workstring, the volume of fluid in the wellbore would be approximately seven times greater if there was no tubing in the well (about 1180 bbls as opposed to approximately 182 bbls). Using the same rate assumption, this subsequently translated to a transit time of fluid in pipe to almost seven times as long pumping down the intermediate casing. The larger volume of fluid in the wellbore would simply be too much to manage.

Pumping down a smaller string should allow more real-time adjustments during the job and fine tuning of the

stimulation treatment. Therefore, the pumping of the stimulation treatment in a smaller string was more feasible. Furthermore, in order to achieve an equivalent transit time in the wellbore without casing, the job would have had to be pumped at an unrealistically high and unsafe rate.

Finally, an early screen out in the 9-7/8-in. casing would require a substantial clean up effort.

Production String Optimization

The nodal analysis indicated that a completion production tubing string would be needed to most effectively and economically produce the well. Because of the substantial cost to trip out the work string, and subsequently, to trip in with production tubing, it was felt by all parties that using the work string as the production tubing string would be more feasible. The extreme downhole temperatures posed limitations in completing with a typical production packer and sealbore configuration. After consideration of all completion factors, an expandable liner hanger (ELH) with a PBR assembly appeared to offer the best solution for meeting the well performance objectives. Conventional hangers use slips and cone technology, which disturbs the flow path around the hanger and can cause cuttings to build up. This can restrict flow, which then can lead to increased equivalent circulating density (ECD). In the worst case scenarios, increased ECD can cause lost circulation, and there is also the possibility that this condition can preset the hanger or packer mechanically.³

When considering the problems listed above, a new expandable liner hanger that had been developed to address the shortcomings of conventional liner-hanger designs, appeared to provide the most appropriate solution for the problematic wellbore scenario.⁴ The liner-hanger body is designed with a clean outer diameter with no moving components. The expandable liner hanger has elastomeric elements bonded onto the body. As the hanger body is expanded, the elastomeric elements are compressed in the annular space. This virtually eliminates the liner hanger/casing annulus and delivers liner-top pressure integrity as well as tensile and compressive load capacity.

The Plan

All parties decided that the best solution was to use the expandable liner hanger with redundant external seals and 40 ft of PBR. In addition to the expandable liner hanger and PBR, a premium high-pressure seal assembly would be run with an internal diameter that would allow full-bore access for perforation tools and composite frac and bridge plugs. The seal assembly on the work string would support choices concerning fracturing and isolation options.

This expandable liner hanger and completion design would allow the optional feature of having capability to run a production packer through the expanded and cemented liner. The PBR seals could be pulled from the well, and a 5½-in. production packer with landing nipples could be run. This would allow isolation and additional zones up hole to be eventually produced.

Typical Advantages to using ELH Technology

Typical advantages^{5,6} in using ELH technology are described below:

The expandable liner hanger reduces risk because *it will not pre-set* when running in the well. This problem has been eliminated by the fact that the hanger does not have mechanical slips. This enables the rig to avoid costly non-productive time and also gain a faster running speed to depth. Another advantage of the expandable liner hanger is the capability to rotate and reciprocate the liner and string to obtain a better cement job and more effectively work through tight spots while running in the hole.

The expandable liner hanger features a gas-tight sealing area with redundant Viton® elements that expand with the steel. The combination of the liner and seals with the service tool design allows for an immediate seal test without tripping pipe. This tool design allows circulation at the liner top to eliminate a second trip into the well to dress off the liner top.

Tool Design Considerations

Before the job was run, there were items to consider in the job design preparation. The design took into consideration the standard expandable liner threads and a transition cross-over to the seal bore. The initial sealbore calculations had stipulated that approximately 33 feet could be required, but to have a polished bore of this length and meet the project timeline required a lead time for equipment outside the scope of the project. The pin thread of the bottom of the liner allowed for box-by-pin sealbore sections. The sealbore could be shortened from a one-piece 40-foot section to two 20-ft sections. These 20-ft sections facilitated make up on location as opposed to picking up such an awkwardly long assembly and making it up on the rig floor.

Considerations Concerning Changes in Temperature and Tubing Movement

Tubing movement is the change of the length of the tubular pipe based on multiple forces and conditions⁷ This movement can be elongation or contraction based on forces when all the factors related to force, pressure, ballooning, buckling, and piston effect are considered. Cooling of the tubular creates contraction or shrinkage movement, while tubing elongation occurs when metals are subjected to friction or high temperature. There are multiple programs available that calculate changes due to temperature and pressure profiles that determine pipe-body movement.

Based on the principles described above, hydraulic fracturing with a cool fluid (cooler than down hole conditions) will result in shrinkage of the tubing during the stimulation treatment.

The initial tubing movement calculations indicated that the temperature change between surface and downhole during the fracturing treatment would cause a substantial amount of shrinkage on the tubing. That movement was based on a surface temperature of 70°F with a tubing movement of approximately 33 feet.

Fig. 2 shows a force diagram that indicates that all forces

during the treatment would be attempting to pump the tubing out of the hole. However, these forces can be counteracted with slackoff weight and with applied annular pressure (see **Fig. 3**), and since the stinger outer diameter would be greater than the tubing outer diameter, applying backside pressure would add weight to the seals, helping to keep the tubing stable in the hole and stung into the ELH and PBR. Thus, by applying slackoff force when the tubing is landed, the seals would not shrink enough to be removed from the ELH and PBR during the stimulation. Care must be taken as too much initial slackoff would buckle the tubing and too much tubular buckling would prevent wireline tool passage. With the tubing size and weight chosen, it was determined that the optimum slackoff weight would be approximately 20,000 lbf. This would most likely cause the tubing to buckle minimally, but would still allow wireline tool passage. The greatest possible tubing movement anticipated (assuming screen-out conditions) would be approximately 35 feet. The 40-foot of PBR chosen for the final configuration was deemed sufficient to cover all contingencies.

Job Summary

For the most part, when the actual job was run, no major difficulties were experienced. Running in the hole, one tight spot was encountered in the openhole section; however, operators were able to effectively break through the section with rotation and circulation. Mud was circulated and conditioned prior to pumping the cement job.

Procedures for expanding the liner follow:

1. a steel ball is dropped to seat and can be pumped down if a rupture disc is used.
2. Once the ball is on seat, pressure will start building in the drill pipe.
3. Pumping is continued at a constant rate in order to initiate the expansion process.

The liner expansion chart from this job is shown in **Fig. 4** and illustrates how each of the elastomer elements are expanded. Also shown in Fig. 4, the bypass can be seen opening as the pressure sharply drops off after the build. Once the bypass is opened, slackoff force is applied to disengage the liner hanger in order to pull up and circulate.

Cost Savings Discussion

The elimination of running the production casing to the surface generated cost savings. The components considered in order to estimate the savings were the 5½-in. production casing from TD to surface, the expandable liner hanger, the PBR, seal assembly, and workstring/production string tubulars. The expandable liner hanger was set at approximately 16,000-ft, thus, eliminating the need for 16,000-ft of 5½-in. casing to surface. The total savings generated from use of the above equipment amounted to approximately \$284,000.

Rig time cost savings are not included in this figure, as no detailed analysis was available that included operational time.

Conclusions

- Challenges in drilling and completing deep Rocky Mountain basins require planning for hydraulic fracturing and production string considerations to prevent well loading during production.
- Completing this deep well with an expandable liner hanger and PBR below proved that considering the production tubular requirements while designing the drilling program optimized the entire completion as a whole.
- Using the expandable liner hanger reduced equipment costs and increased operational efficiency compared to conventional liner hanger systems.

Acknowledgments

The authors wish to thank Halliburton Energy Services, Inc., for their encouragement and permission to publish this paper. The authors also wish to acknowledge the engineering project team for their contributions to the successful development of this system as well as the operators who allowed its efficiency to be proven in the field.

The authors also appreciated the help provided by Mr. Pat Kundert, Mr. Troy Schindler, Mr. Raymond Meijs, Mr. Tance Jackson, and Mr. Kenny Sanders for their involvement and technical guidance in design and running of this job.

References

- 1 LeGrand, F., Parrott, K., and Enterline, T.: "Cave Gulch Field, Natrona County, Wyoming: Focus Returns to the Deep Objectives." *The Mountain Geologist*, Vol 43, No. 3 (July 2006) p. 171-176.
- 2 Eberhard, M., Meijs, R.: Application of Flow-Thru Composite Frac Plugs in Tight-Gas Sand Completions, paper SPE 84328, presented at the SPE Annual Technical Conference held in Denver, CO, U.S.A., October 5-8, 2003.
- 3 Walvekar, S., Jackson, T.: Development of An Expandable Liner Hanger System to Improve Reliability of Conventional Liner Hanger System, paper SPE 99186, presented at the IADC/SPE Drilling Conference held in Miami, Florida, U.S.A., February 21-23, 2006
- 4 Cantu, J., et al.: "Expandable Liner Hanger Application in Arduous Well conditions Proves Reliability," paper SPE 88510 presented at SPE Asia Pacific Oil and Gas Conference, Perth Australia, 18-20 October 2004.
- 5 Lohoefer, C., et al. "Expandable Liner Hanger Provides Cost-Effective Alternative Solution," paper IADC/SPE 59151 presented at IADC/SPE Drilling Conference, New Orleans, Louisiana, 23-25 February 2000.
- 6 Nida, R., Meijs, R., Reed, S.: Innovative Expandable Liner-Hanger Application Saves Time on Pinedale Anticline Drilling Operations: Two Case Studies, paper SPE 90192, presented at the SPE Annual and Technical Conference held in Houston, Texas, U.S.A., September 26-29, 2004.
- 7 Hammerlindl, D.J.: Packer to Tubing Forces for Intermediate Packers, *Journal of Petroleum Technology*, March 5-8, pgs 515-527. 1980 SPE of AIME

SI Metric Conversion Factors

$$\begin{aligned} ^\circ\text{F} (\text{ }^\circ\text{F} - 32)/1.8 &= ^\circ\text{C} \\ \text{ft} \times 3.048^* &= \text{m} \\ \text{in.} \times 2.54^* &= \text{cm} \\ \text{psi} \times 6.894\ 757 &= \text{kPa} \\ \text{lbf} \times 4.448\ 222\text{E} + 00 &= \text{N} \end{aligned}$$

*Conversion factor is exact

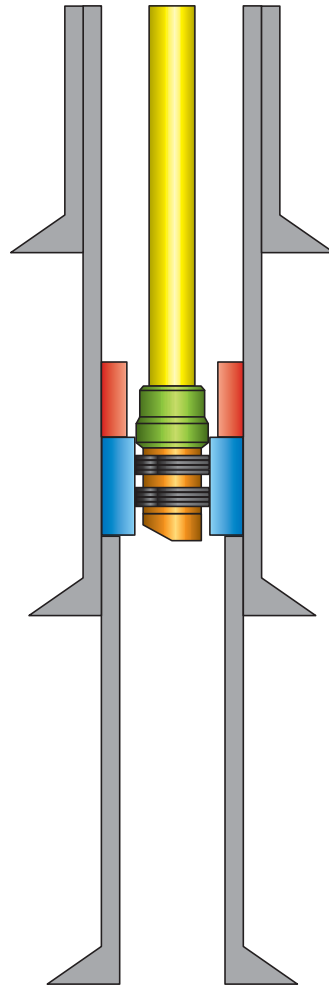

Fig 1. — Sketch of wellbore completion concept.

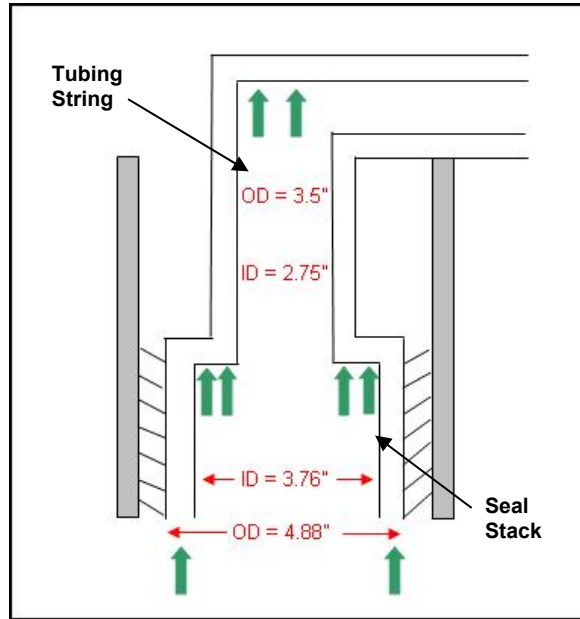

Fig. 2. — This diagram shows the large OD of the seal stack connected to the tubing string. The green arrows indicate areas where force will be applied during pumping operations on the well.

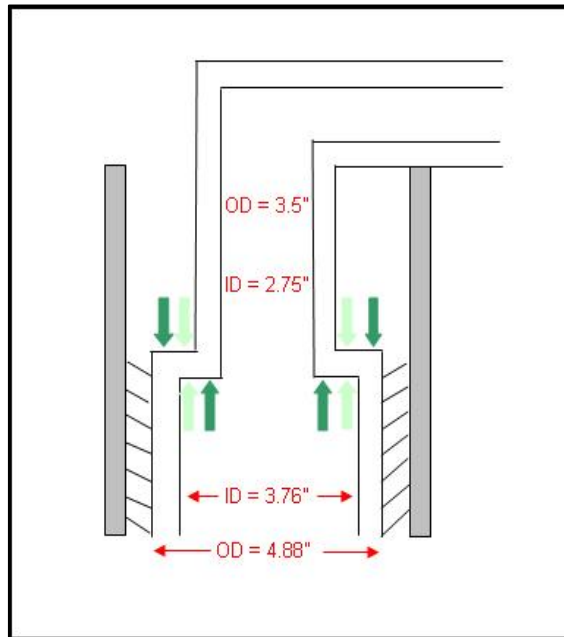

Fig. 3 — Diagram is illustrating forces of applied annular pressure. Effected area is seal outer diameter area minus area of tubing outer diameter. Therefore, any applied annular pressure will add weight to the seals. This is one mechanism that could be used to help alleviate tubing movement during either the stimulation treatment or during production. Arrows indicate area where force will be applied with a fluid filled tubing string and applied annular pressure. Light green arrows indicate forces that will be cancelled out by each other when tubing is full of fluid and fluid is also in the annular space outside the tubing on the backside.

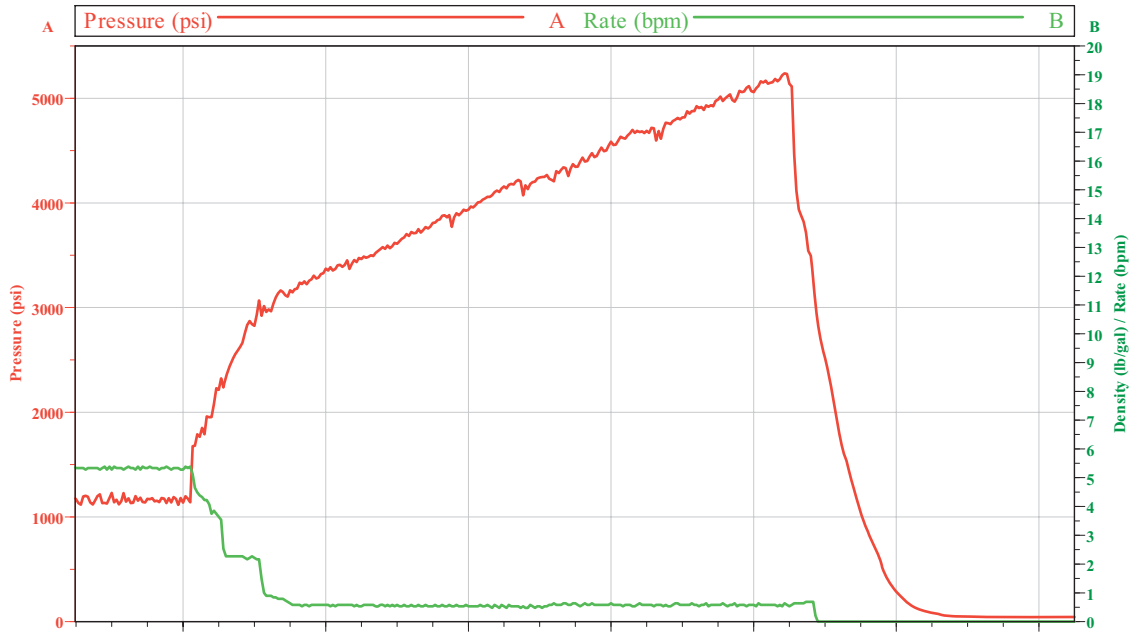

Fig. 4. — This chart shows the actual liner hanger expansion. Each sharp dip in pressure (red line) represents one of the five elastomers expanding. The green line represents rate. Rate is held constant until pressure starts to build. When pressure builds, elastomers will expand; when this occurs, pumping rate can be dropped.