



Slender Well Plan for Lower Cost and Improved Safety

Nader Sheshtawy and Adel Sheshtawy, TRI-MAX Industries

This paper was prepared for presentation at the AADE 2005 National Technical Conference and Exhibition, held at the Wyndam Greenspoint in Houston, Texas, April 5-7, 2005. This conference was sponsored by the Houston Chapter of the American Association of Drilling Engineers. The information presented in this paper does not reflect any position, claim or endorsement made or implied by the American Association of Drilling Engineers, their officers or members. Questions concerning the content of this paper should be directed to the individuals listed as author/s of this work.

Abstract

This paper outlines the Slender Well Plan (SWP) concept highlighting the economic and safety advantages of the SWP. This paper will also describe the available simultaneous drilling and underreaming (SD&UR) tools to execute a successful SWP. Slender Well Plans will allow the industry to shed the extra cost of our traditional well plans.

Introduction

We have traditionally designed well plans from the bottom up especially for development wells. The optimum production casing or liner size is the controlling factor. The number of casing strings required to safely reach the pay zone are dictated by the geological sections to be drilled. Current deep wells require several intermediate casings or liners.

The Slender Well Plan (SWP) provides the largest production casing size using smaller diameter intermediate and surface casing sizes as compared to a traditional well plan (TWP). Smaller intermediate casing sizes will reduce overall well costs and improve well safety. The SWP currently being used in some deep offshore wells have proven John Barker's statement that, "The rule-of-thumb relied upon in TWP to determine the clearance between casing strings are often found to be conservative or out of date" [1]. The SWP could not be economically achieved ten years ago due to the non-availability of effective SD&UR tools.

Seven years ago, Tri-Max Industries pioneered the development of a fail safe concentric Enlarge While Drilling (EWD) tool which simultaneously drills and underreams (SD&UR) [2]. In the last 5 years, two additional SD&UR tools were introduced to the drilling industry. Several other tools are currently under development.

What is a Slender Well Plan?

The Slender Well Plan delivers the largest possible production casing or liner size while reducing the size of the intermediate and surface casing strings as compared to the traditional well plan (Fig. #1).

The successful execution of a SWP to achieve the maximum cost reduction depends on the case and correct application of SD&UR tools.

Economic Advantages of SWP

One of the intermediate casing strings for deep wells is the heaviest load handled by a drilling rig. In our example well, the 13 3/8" casing weight is approximately 1,000,000 pounds and at least a 1,200,000 pounds plus hoisting capacity rig is required to drill this well. The SWP can be drilled by a rig with less than 1,000,000 pounds hoisting capacity. Admittedly, the 13 3/8" casing string in our example well can be run as a liner with a tie back. Another alternative is to partially float the 13 3/8" casing string, but this will add a slightly higher risk factor and cost. The volume of cement, mud and cuttings to dispose of are important additional factors to be considered in the cost of the two types of well plans besides the noticeable cost savings of using smaller drilling tools and running smaller tubular sizes (Fig. #2). The estimated percentage savings for the different well cost elements for the SWP versus a TWP are shown in Table #1.

Safety Advantages of the SWP

A smaller diameter casing has a higher internal yield pressure (bursting pressure) than a larger casing size. In our example well, the 13 3/8" (77 lbs/ft) casing has internal yield pressure of 6,390 psi while the 11 3/4" (60 lbs/ft) casing has internal yield pressure of 6,920 psi. This is almost a 10% increase of the intermediate casing string capacity to handle a kick.

The SWP will allow the use of an 18 5/8" riser and subsea stack while a TWP will require 22" riser and BOP stack for the top part of the well which will have to be changed later to 18 5/8" stack and riser for higher pressure rating.

In our example, the higher internal yield pressure of the 11 3/4" casing may allow the running of a 9 5/8" liner. By contrast, the lower internal yield pressure of the 13 3/8" casing may dictate running the 9 5/8" as a casing to surface. The running 9 5/8" liner in a SWP allows the use of a tapered drill string of 6" and 5" drill pipe giving lower friction pressure losses in the drill pipe and higher overpull capability. On the other hand, the 9 5/8" casing in a TWP dictates the use of 5" drill pipe only.

Simultaneous Drilling and Underreaming (SD&UR) Tools Available for SWP

SD&UR tools developed in the last seven years

include the Enlarge While Drilling (EWD), Near Bit Reamer (NBR) and Rhino Reamer (Rhino). These tools represent the corner stone for successful implementation of a SWP.

These new SD&UR tools have proven their advantages over bi-center bits (winged reamers) and flip arm underreamers. The following are descriptions of the strength and limitations of these tools:

Hydraulic activated Flip Arm Underreamers (FAUR)

- The basic FAUR design has existed from the early days of the drilling industry.
- The FAUR was used mainly for underreaming soft, unconsolidated pay zones for gravel packing and underreaming large surface holes due to limited circulating volumes of older rigs (**Fig. #3**).
- FAUR pose a high risk due to the potential of breaking an arm or the total body (**Fig. #4**).
- The FAUR is also an expensive option because a separate underreaming run must be done at slow ROP.

Bi-Center Tools (Winged Reamers)

Bi-center bits got their start as early as the 1950s. This tool was used mainly in formations with a high tendency for sticking problems. In this application, a somewhat larger hole size allowed sufficient clearance to retrieve the bit and bottom hole assembly (BHA).

- The major advantages of bi-center tools, as compared to the FAUR, are their one piece construction and the reduced risk of losing large junk in the hole (**Fig. #5**).
- The main disadvantages of bi-center tools are inconsistent hole sizes and limited application in medium and hard formation.
- A major problem is excessive fluctuating torque and the damaging effect on the motor, MWD, LWD and rotary steerable system caused by the resulting extreme shocks and vibrations.
- Another consequence of the bi-center style bits is directional control. The basic design principle of cutting with a winged reamer blade, which is only on one side, leads to poor directional control and wasted rig time correcting for this.
- Another well known limitation of drilling with bi-center bits is a spiral well bore.
- Recent improvements in the bi-center design have not entirely eliminated these limitations [**3**].

Concentric Designed SD&UR Tools

The three available concentric SD&UR tools in the market today differ significantly in design, length, safety and performance. All concentric SD&UR tools run with a full gauge pilot bit as compared to a bi-center style bit which uses a small pilot bit in order to be able to pass

inside the casing.

- The Rhino Reamer (Rhino) was introduced to the drilling industry just over two years ago (**Fig. #6**). The Rhino is a pressure activated tool using a hybrid design of a pressure activated production packer and the FAUR. The Rhino has a large outside diameter (OD) and longer tool length as compared to the other two concentric tools. The Rhino has three large symmetrical cutters with limited support due to the space requirement of the pressure activation mechanism. The length of the Rhino prevents its application below a directional motor.
- The Near Bit Reamer (NBR) was introduced to the drilling industry around four years ago. The NBR uses three spring loaded, elongated, curved plates with small cutter pads. The mud flow forces the three plates and the attached cutters outward to the reaming diameter of the tool (**Fig. #7**). The pressure supported cutters tend to move radially inward and outward due to the drilling string's non concentric rotation. The NBR cutter movement generates a pressure variation which can hinder the MWD & LWD signal transmission and cause wear and failure of the O-ring seals of the cutter pads. Also, the three cutters pads are individually activated sometimes leading to activation of only two cutter pads.
- The Enlarge While Drilling Tool (EWD) was introduced to the drilling industry in 1997. The EWD has more than 400 field runs over the last six years. It is the first concentric SD&UR and the only weight activated one. The simple mechanical design of the EWD has been successful in running on rotary, below a directional motor and rotary steerable BHAs. The EWD design has been continuously improved from the first generation introduced in 1997 (**Fig. #8**) to the current fifth generation (**Fig. #9**) EWD design with numerous modifications to meet various drilling requirements [**4**]. Applications have included soft to hard formations in varying well profiles from vertical to horizontal. Once in the drilling position, the EWD has no temperature or pressure limitations due to the metal-to-metal seal (similar to a well head flange seal). The EWD has been run in wells with temperatures just below 400°F. The current generation of EWD tools can easily be modified to a variety of tripping and drilling sizes by changing the three cutter blocks. These size modifications are adapted to different casing drift diameters and cement thickness requirements around the casing string. Numerous specialized SD&UR tools have also

been developed and run to meet focused drilling objectives in extreme well programs (Fig. #10).

Conclusions

- The SWP will allow the oil industry to shed the extra cost associated with the TWP.
- The SWP will result in a larger production casing as compared to the TWP while at the same time reducing both the surface and intermediate casing sizes.
- The cost savings of the SWP are primarily due to the lower costs of smaller casing, less mud, less cement and fewer cuttings to handle as compared to the TWP.
- SWP are currently being used in deepwater wells generating an enormous cost savings due to the high operational costs.
- The application of SWP in land operation is gaining acceptance due to the performance of current SD&UR tools.

Acknowledgments

The authors wish to thank the numerous drilling engineers and personnel for their input and comments on this paper.

Nomenclature

| | | |
|-------|---|---|
| SWP | = | <i>Slender Well Plan</i> |
| TWP | = | <i>traditional well plan</i> |
| BHA | = | <i>bottomhole assembly</i> |
| SD&UR | = | <i>simultaneous drilling and underreaming</i> |
| ROP | = | <i>drilling rate of penetration</i> |
| WOB | = | <i>weight on bit</i> |
| FAUR | = | <i>hydraulic activated flip arm underreamer</i> |
| NBR | = | <i>near bit reamer</i> |
| EWD | = | <i>Enlarge While Drilling</i> |

References

1. Barker, J. W.: "Wellbore Design with Reduced Clearance between Casing Strings," SPE/IAADC 37615 presented at SPE/IAADC conference in Amsterdam, Netherlands, 1994.
2. Sheshtawy, A., and Howell, M.: "Cut Costs with New BHA for Reduced Clearance Casing Programs," *World Oil*, December 1999, pgs 59-62.
3. Beaton, T., and Hudspeth, D.: "Advanced Technologies Increase Hole Opening Efficiency," paper ETCE 2001 conference in Houston, Texas, February 5-7, 2001.
4. Sheshtawy, A., Sheshtawy, N., Isa, N., and Payne, L.: "Field Experience with Advanced Design Hole Opening Tools," paper AADE-03-NTCE-34 presented at AADE Conference in Houston, Texas, April 2003.

Table #1**Slender Well Plan Percentage Savings Compared to Traditional Well Plan**

| Well Cost Component | SWP % Savings |
|---------------------------------------|----------------------|
| | |
| Casing | 28% |
| Cement & Casing Accessories | 30% |
| Mud, Cutting Transport & Treatment | 44% |
| Rig and Rental Tools | 20% |
| | |
| Total Savings (Approximate) | 20% |

TRADITIONAL WELL vs. SLENDER WELL

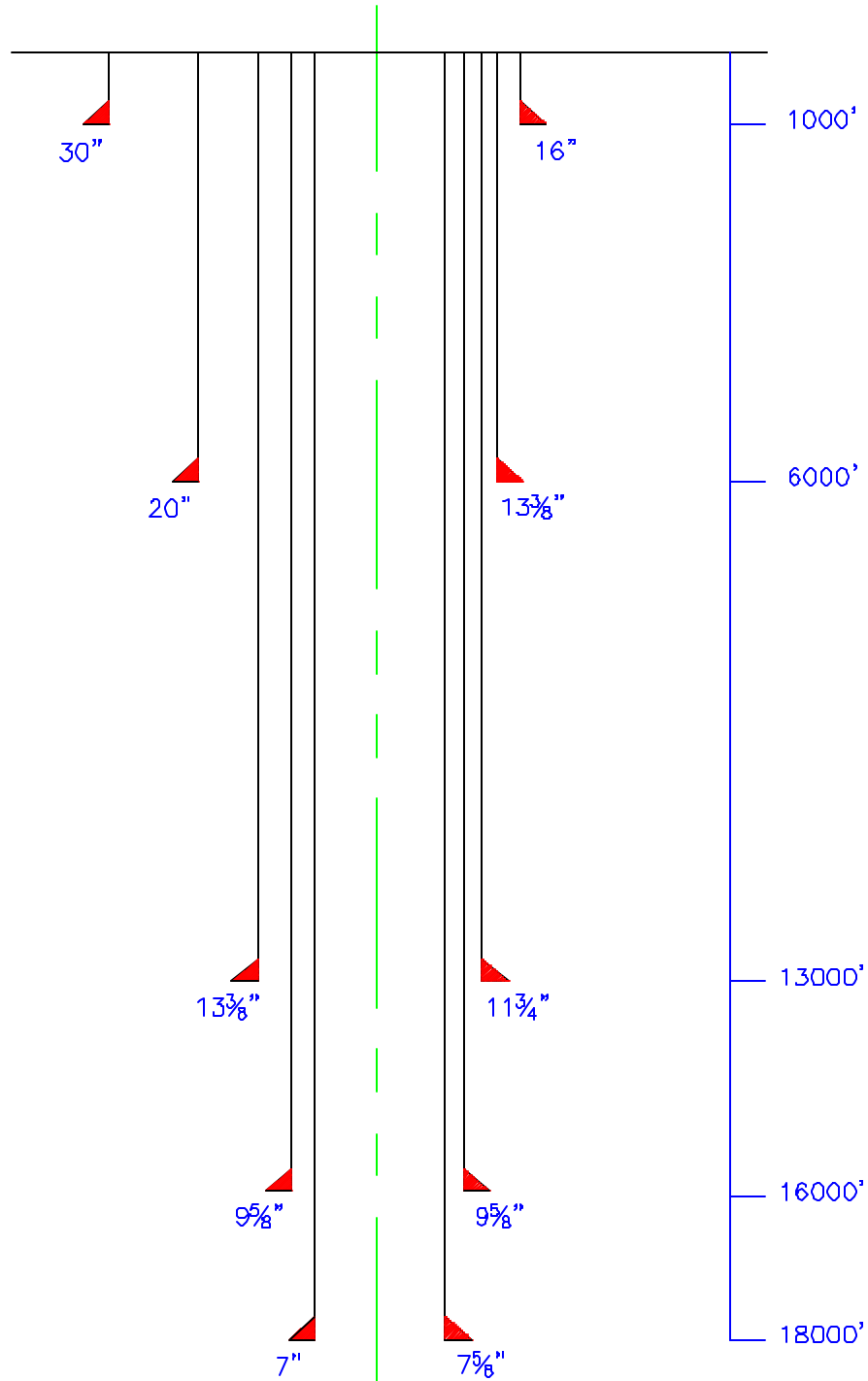
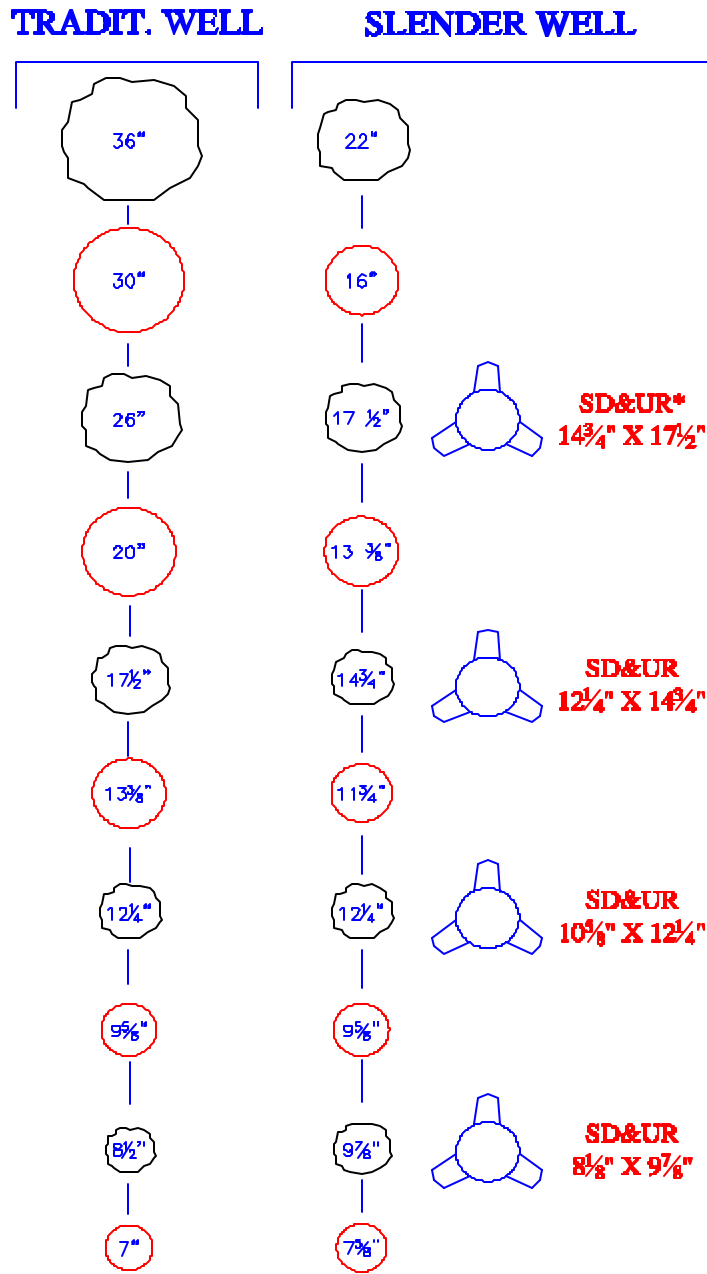

Figure (1) - An Example Casing Plan of the SWP versus TWP

HOLE-CASING SIZES CHART



 HOLE SIZE
  CASING SIZE

*** SD&UR = Simultaneous Drilling & Under-Reaming tool**

Figure (2) – Hole Size and Casing Size of the SWP versus TWP for the Example Well



Figure (3) – Hydraulic Activated Flip Arm Underreamer



Figure (4) – Flip Arm Broken in Half



Figure (5) – Bi-Center / Winged Reamer – New versus Used



Figure (6) – Rhino Reamer

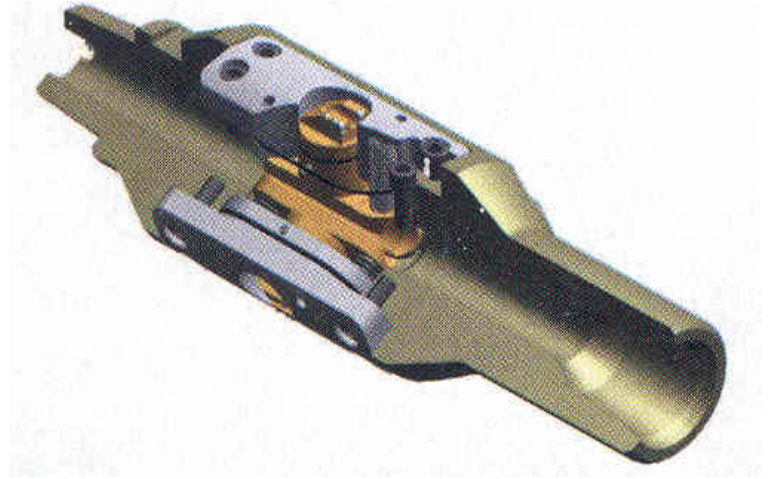

Figure (7) – Near Bit Reamer

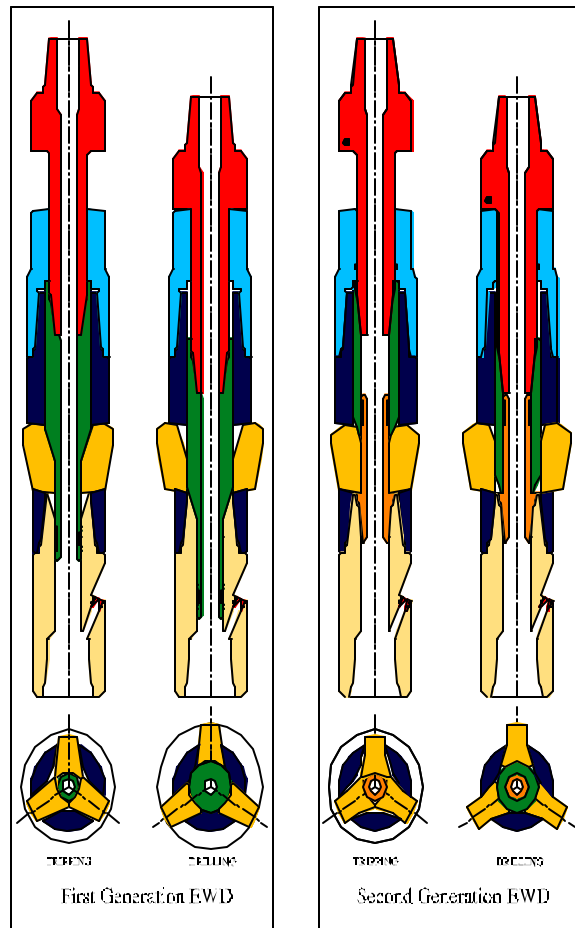

Figure (8) – 1st Generation EWD as Compared to 2nd Generation EWD



Figure (9) – 5th Generation EWD with Protected Locks



Figure (10) – Tri Bit Reamer