

SOLUTIONS FOR TORQUE, DRAG, AND EXTENDED REACH CT OPERATIONS



WWT International

Joey Hopper

Contact: 281-345-8019, jhopper@wwtco.com

Alaska Energy Resources (WWT's Agent)

Contact: 907-336-4664

Non-Rotating Protectors



FlexShoe



CT Tractors



Corporate History

- WWT is a private company established in 1989
- It's core is Engineering, we specialize in developing innovative tools for drilling, completion and intervention.
- Headquartered in Houston, Texas
- R&D in Anaheim, California
- Worldwide Operations
- Three key business groups
 - WWT International Engineering Services
 - WWT International Coiled Tubing Services
 - WWT International Drilling Tool Services
- Locally represented by Alaska Energy Resources

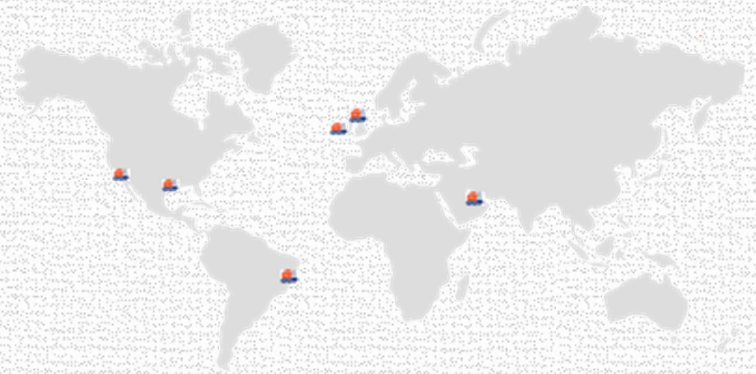

Non-Rotating Protectors (NRP)



- Developed in 1989 and continuously improved since, as a result of thousands of applications and closely working with customers.
 - Improvements now include open hole use and MPD compatible.
- Used on 80+ wells in Alaska by various operators: Apache, BP, Chevron, ConocoPhillips, Cook Inlet Energy, ENI, Hilcorp, Pioneer, and Unocal.
- Installed directly onto the drill pipe providing placement flexibility for the application.
- WWT provides T&D Modeling, and onsite service technicians to achieve well specific solutions.
- No well has ever been sidetracked or abandoned due to WWT Non-Rotating Protectors.

NRP Benefits

- **Casing Protection:** stand-off protection of each tool joint that enters the high contact force area of the wellbore.
- **Torque Reduction:** reducing the rotational friction by installing a “bearing” (NRP) at each joint where friction is occurring thus improving drilling efficiency and performance.
- **Drag Reduction:** reducing the sliding friction by installing a low friction protector in the areas experiencing steel on steel contact.
- **Riser Protection:** creating a stand-off between the tool joint and riser/flex joint for offset wellheads or when loop currents are present.
- Other benefits often include reduced stick-slip and vibration, and increased ROP.
- Applications for Alaska include ERD, sidetracks, multi-laterals, buckling mitigation, liner runs, and steerable liner drilling

WWT NRP Installation

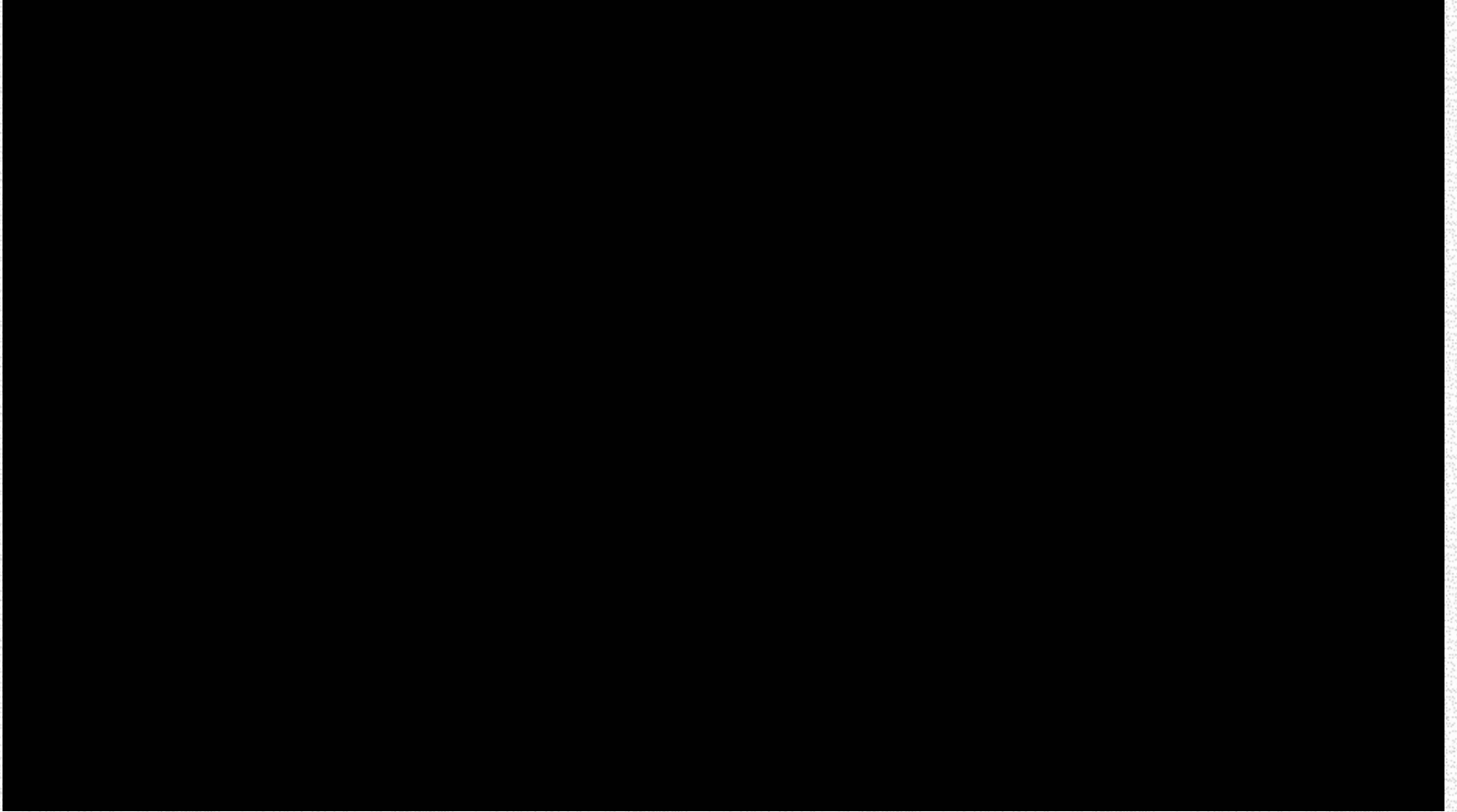

SS Vs. SS3 Protector Comparison

SS Model

- Designed for cased hole only
- 220°F max temp rating
- Standard collars has 3 bolts
- Both models have the same fluid bearing technology
- Polyurethane sleeve body



SS3 Model

- Designed for cased and open hole
- 220°F max temp rating
- Standard collars have 4-5 bolts
- Smoother angle on collar and sleeve to be better compatible with MPD operations
- Low friction polymer sleeve body



MPD Improvements

- WWT has successfully stripped protectors through 3 brands of RCDs at pressures up to 700psi.
- Added seal between bolts, and prototype “mirror” style collars.



Collar with seal between bolts

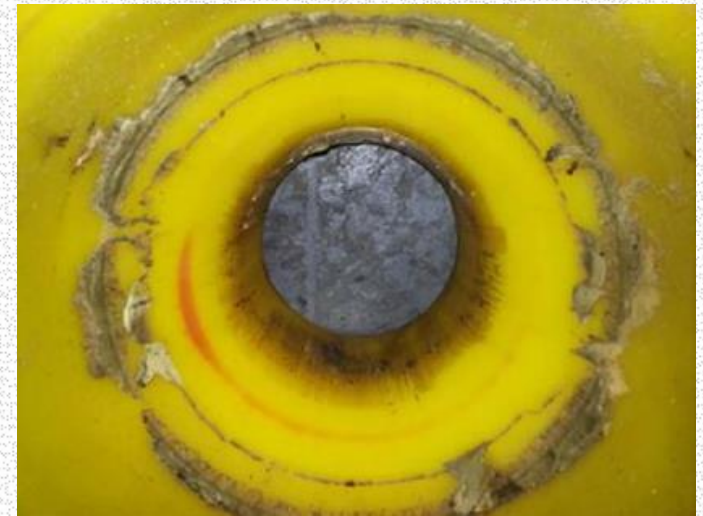

After 400 passes with a 5-7/8” protector @ 400 psi



After 60 passes with a 4” protector @ 700 psi.

Modeling and Placement

- WWT provides T&D and casing wear analyses at no cost to determine optimum location for NRP placement and prediction of benefit.
- Numerous modeling methods, including soft string, stiff string, beam element FEA, etc.
- Engineers also examine operational risk to ensure successful deployment of NRP.
- Placement quantities and location can be adjusted to meet customer specific goals.

| Area of Concern | Placement MD: Start of Run | | | Placement MD: End Of Run | | | Protectors Per Joint | Protector Quantity | Model |
|-----------------|----------------------------|-----|--------|--------------------------|------|--------|----------------------|--------------------|---------|
| | Zone | Top | Bottom | Joints | Top | Bottom | | | |
| A | 0 | 85 | 3 | 1500 | 6150 | 150 | 1 | 150 | SS3-400 |

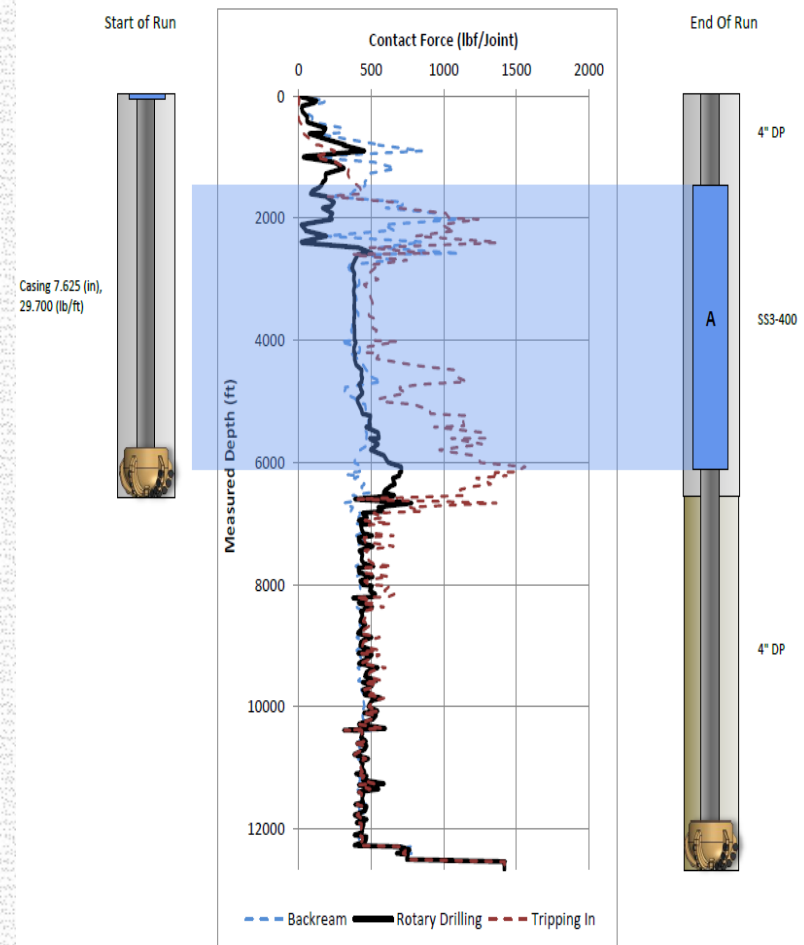

North Slope Torque Reduction Case History

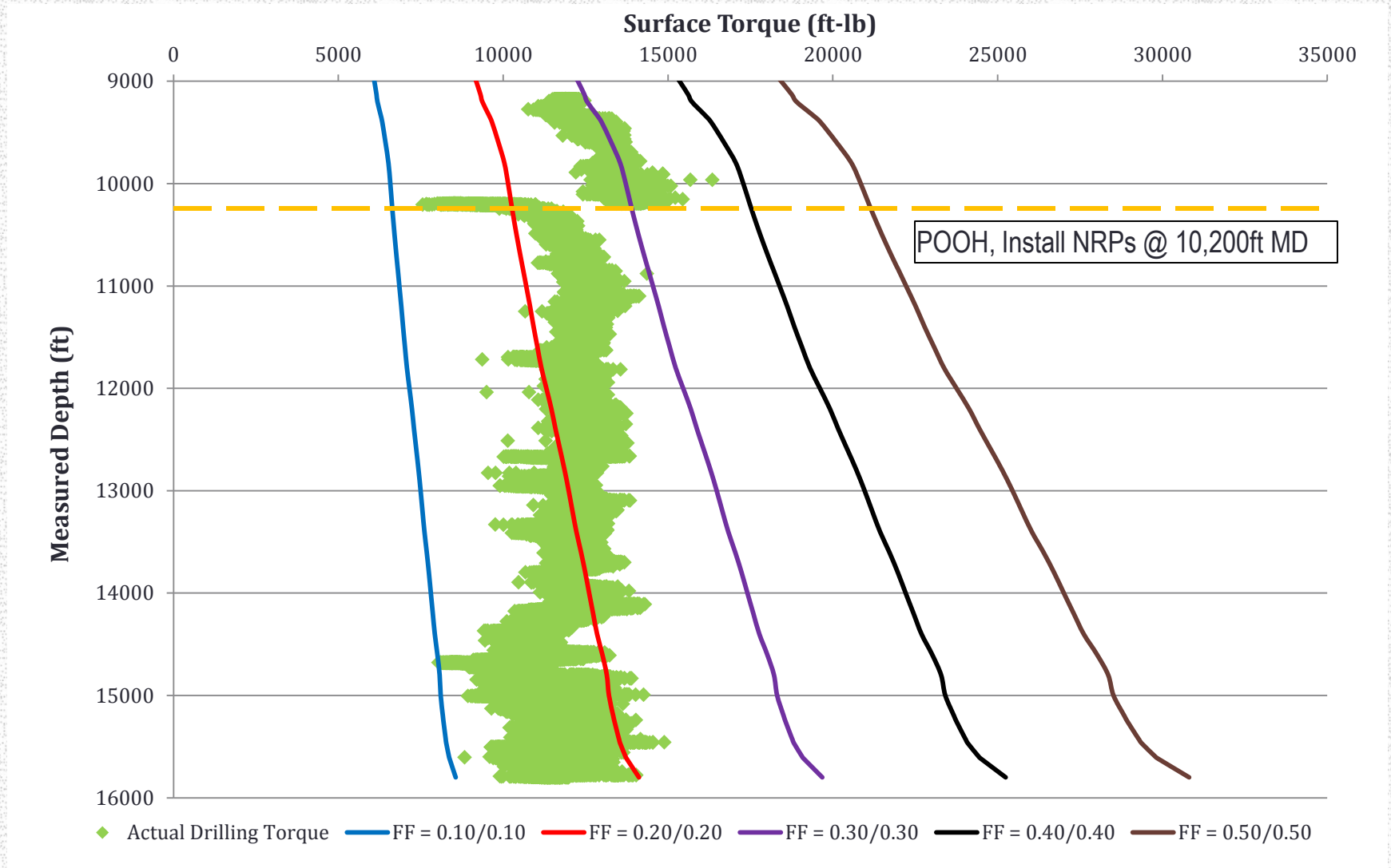

WWT has observed torque reductions over 35% on several occasions for NRP applications in Alaska.

ERD Case History

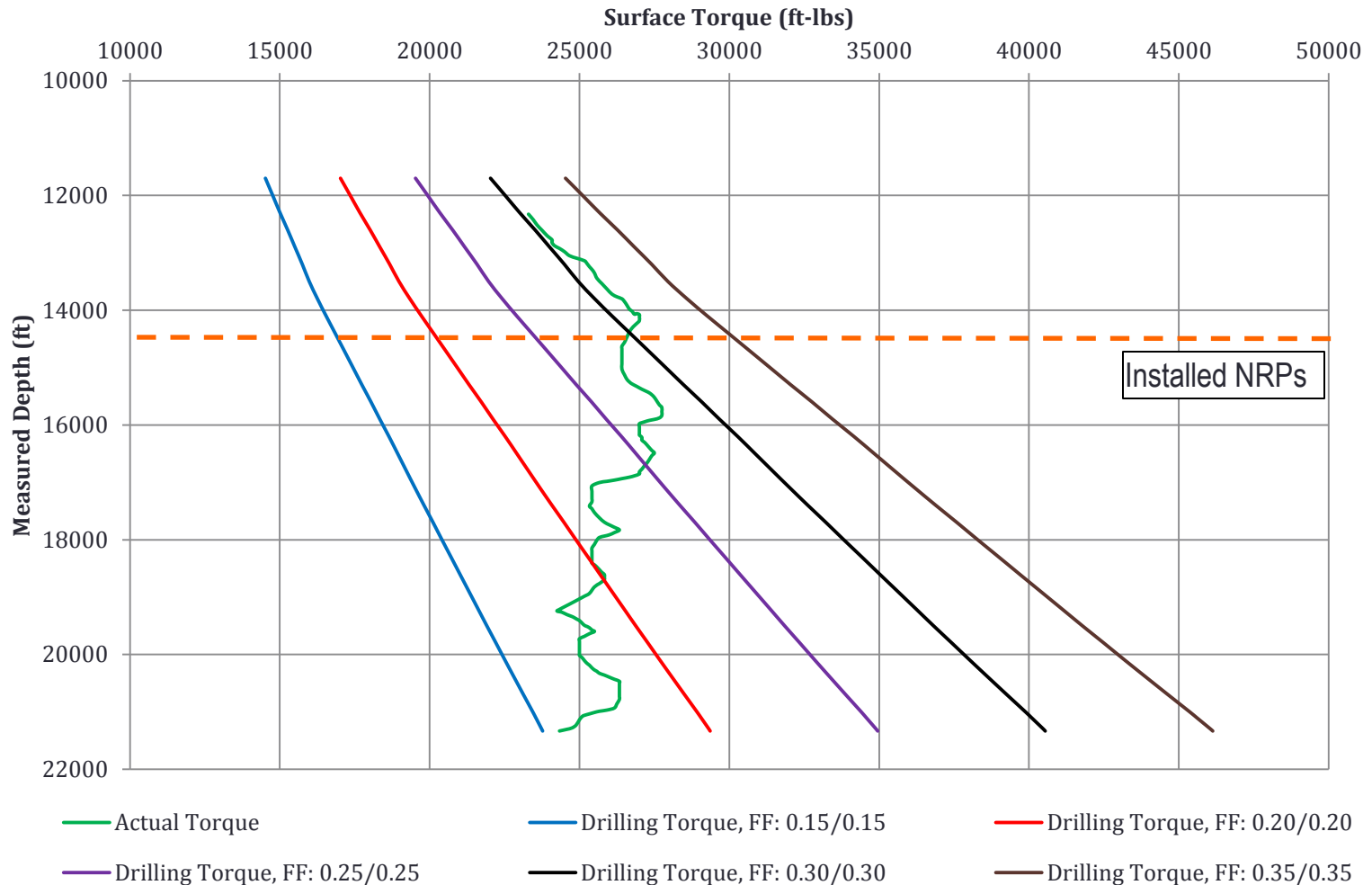

This data suggest NRPs reduced torque by approximately 38% @ TD.

WWT FlexShoe



Why FlexShoe?

When running through dog-legs, side loads are concentrated at the end of the casing. This increases risk of hanging up when RIH.

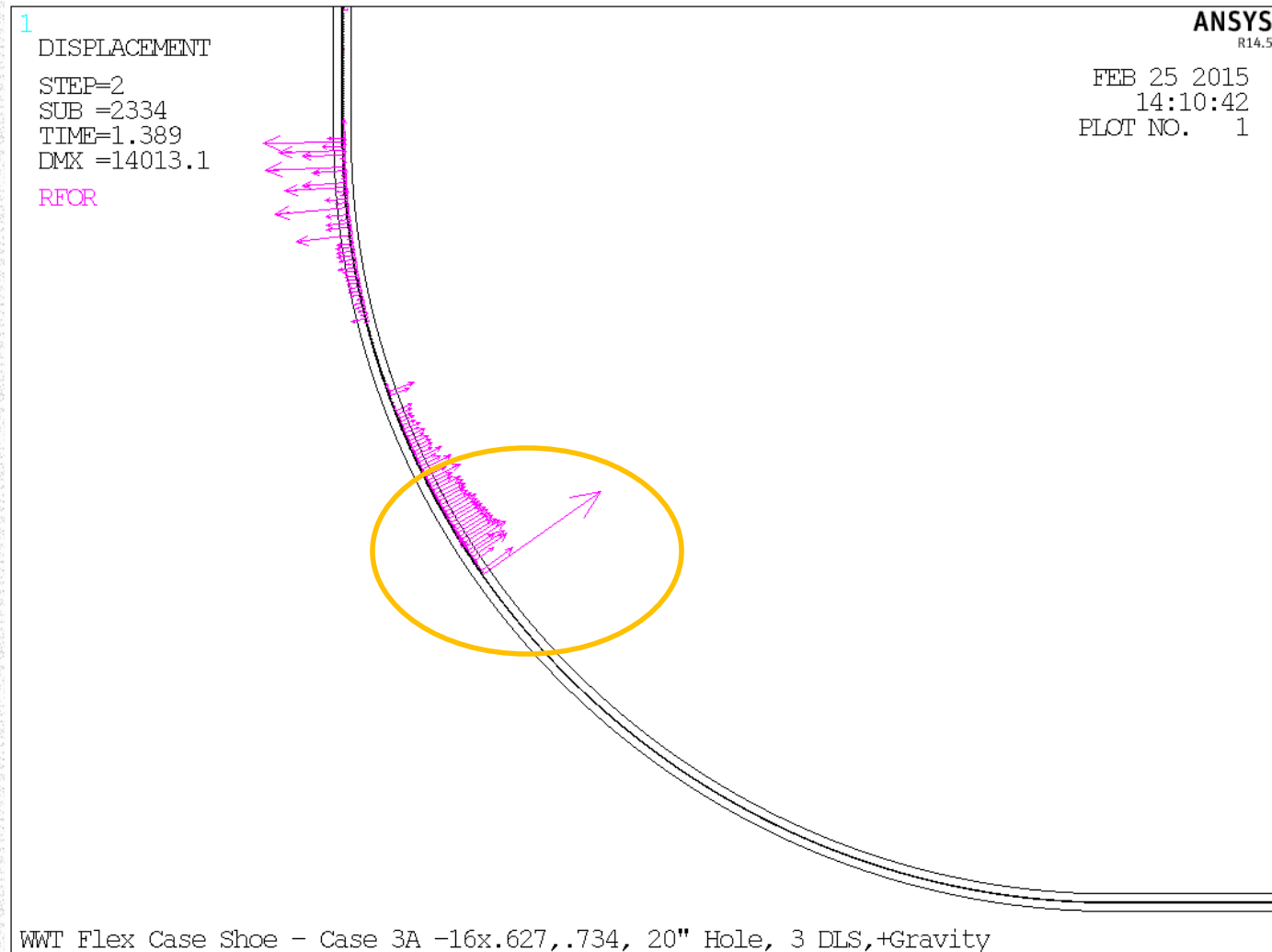

Why FlexShoe?

FlexShoe reduces bending loads at the casing shoe by more than 90%, and spreads out bending loads to enable the shoe to run past trouble areas.



WWT FlexShoe



Flexible yet strong composite tube capable of supporting significant side and compressive loads.

Unique coupling design enables transition from high stiffness casing to flexible shoe while keeping stresses low.

Drillable nose. Additional nozzle and flow configurations are available.

The materials used in the manufacture of the FlexShoe are drillable.



Nose Design

Several nose configurations available depending on well conditions:

- Polyurethane provides flexibility and impact resistance.
- TFA can be adjusted to meet customer needs.
- Aluminum or cement composite can be used in higher temperatures.
- Slots and ribs on nose help prevent rotation of cement or tool.
- Reamer shoe version allows reaming while still being completely drillable without the use of carbide, steel, or PDC.



Standard Poly Nose



High Temp Nose



Reamer Nose

Test Program

- WWT FlexShoe went through a major operator approved analysis and test program before being approved for offshore operations.
- Testing:
 - Compression
 - Bending
 - Torque
 - Pressure (Burst)
 - Wear resistance
 - Material capability
 - Modelling of combined stress states.



Case History – Horizontal Well, Permian Basin

- 7in FlexShoe run inside 9-5/8in casing and 8-3/4in open hole.
- Target TD 11,600ft MD at 85° inclination.
- Max DLS: 20°/100ft
- No problems running casing to target depth.
- Drill out with 6-1/8in bit for a 5,000ft lateral.
- Max 50k set down weight, with 150k to 200k to get to bottom on adjacent well from same pad.
- No problems drilling out of shoe. It took far longer to drill plugs and floats than it did to drill out of FlexShoe.



Coiled Tubing Products

Tractors

- 2-1/8" 3,400lb Force
- 3" 5,150lb Force
- 3-3/8" 6,250lb Force
- 3-1/2" 9,200lb Force
- 4-3/4" 14,500lb Force

Stand Alone Products

- COS Clean Out Sub
- ICS Isolating Circulation Sub
- RCS Repeating Circulation Sub
- ACS Anti-Compression Sub



WWT Tractors

- Features an all-hydraulic control system that delivers increased reliability for extended operations.
- High capacity pulling power, enabling the delivery of heavy tool strings to the outer zones of extended reach wells.
- Ideal for coiled tubing delivered perforating (pressure pulse, or ball drop fire compatible), wellbore cleanout, acidizing, milling, and logging operations.
- Features an exclusive design that allows for ball drop or e-line pass through flexibility for tools positioned below the WWT tractor.
- Constructed of non-magnetic and acid / H₂S resistant materials.

WWT Tractor Gripper Toe

WWT International's patented reciprocating Tractor utilizes a static gripper assembly that performs over a wide range of wellbores.

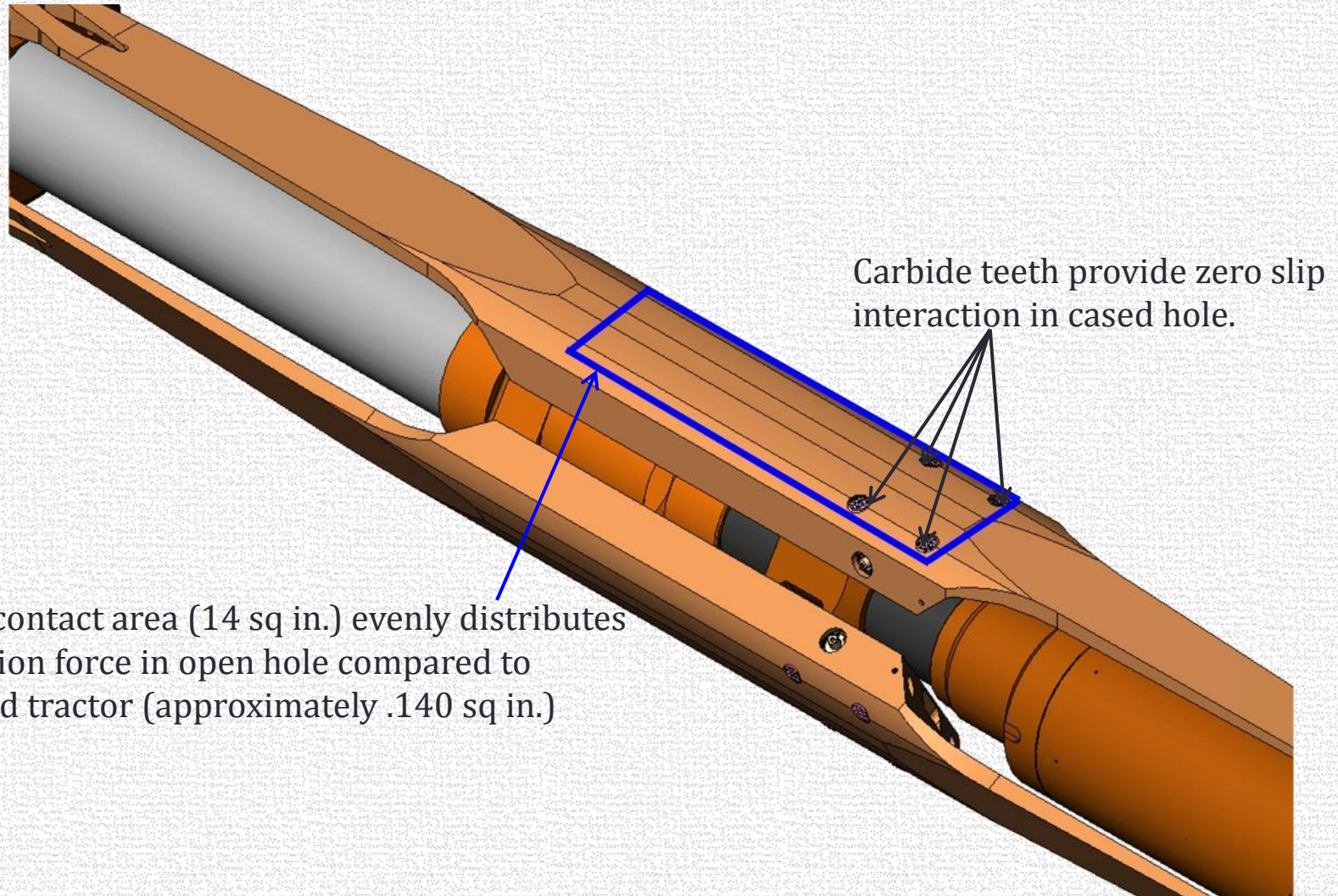

Carbide teeth provide zero slip interaction in cased hole.

Broad contact area (14 sq in.) evenly distributes expansion force in open hole compared to wheeled tractor (approximately .140 sq in.)

WWT International's gripper assembly provides a broad footprint that allows the Tractor to traverse dirty wellbores and not dig into open hole formations.

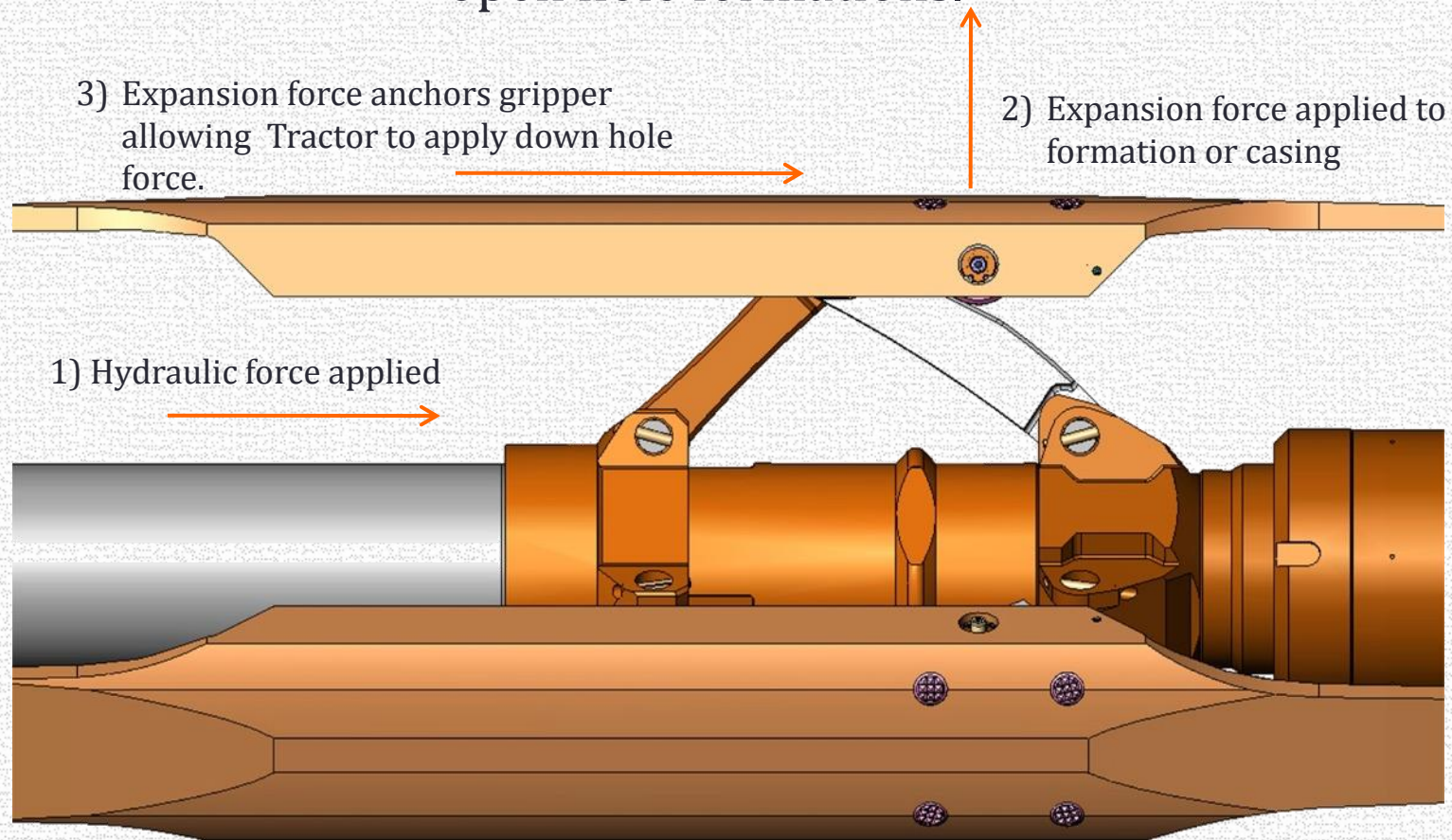

Tractor Specifications

| Tractor Models | 470 | 350 ERG | 350 EEG | 338 | 388 | 300 | 212 |
|--|-------------------------------------|--------------|-------------------------|--------------|--------------|--------------|--------------------------|
| Tractor OD, Gripper Collapsed (in.) | 4.7 | 3.5 | 3.5 | 3.38 | 3.88 | 3 | 2.125 |
| Tractor ID (in.) | 0.8 | 0.5 | 0.5 | 0.75 | 0.75 | 0.5 | N/A |
| Total Length (feet) | 27.5 | 23.9 | 23.9 | 22.6 | 22.6 | 23.9 | 14 to 20 |
| Wellbore Operational Range (in.) | 5.2 to 8.5 | 4.0 to 7.4 | 3.9 to 4.1 8.5 to 12 | 3.8 to 4.2 | 4.2 to 5.1 | 3.5 to 5.2 | 3.9 to 4.1 6.0 to 7.4 |
| Maximum Operating Differential Pressure (psid) | 1700 | 1700 | 1700 | 1500 | 1500 | 1500 | 2300 |
| Fluid Consumption at 1000 Ft/hr (gpm) | 15 | 7 | 7 | 7.3 | 7.3 | 6 | 6 |
| Maximum Pull (lbs.) | 14,500 | 9,200 | 9,200 | 6,250 | 6,250 | 5,150 | 3,500 |
| Maximum Speed (ft./hr.) | 1,000 | 750 | 750 | 1,000 | 1,000 | 750 | 720 |
| Maximum Overpull (lbs.) | 69,000 | 60,000 | 60,000 | 69,000 | 69,000 | 54,000 | 22,000 |
| Maximum Temperature (° F) | 300* | | | | | | |
| Materials of Construction | Inconel, BeCu and Stainless Steel * | | | | | | |
| Connection | 2-3/8 PAC | 2-3/8 PAC | 2-3/8 PAC | 2-3/8 PAC | 2-3/8 PAC | 2-3/8 PAC | 1.5 AMMT |

* WWT Tractors can be configured to perform in operating temperatures up to 392°F and 60% H2S

Thank You!

Non-Rotating Protectors



FlexShoe



CT Tractors



Industry Papers:

1. Overcoming Weight Transfer Challenges in Complex, Shallow Extended Reach Wells on Alaska's North Slope – OTC 19550
2. Comparing the Results of a Full-Scale Buckling Test Program to Actual Well Data: New Semi-Empirical Buckling Model and Methods of Reducing Buckling Effects – SPE 144535-PP
3. Extending the Operational Window During Gulf of Mexico Loop Currents – July 2006 Issue of World Oil Magazine
4. Improving Casing Wear Prediction and Mitigation Using a Statistically Based Model – SPE 151448-MS