



Harnessing the power of extreme velocity

- An Offering Statement regarding this Offering has been filed with the SEC. The SEC has qualified that Offering Statement, which only means that the Company may make sales of the securities described by the Offering Statement. It does not mean that the SEC has approved, passed upon merits or passed upon the accuracy or completeness of the information in the Offering Statement. The Offering Circular that is part of that Offering Statement can be found at: <https://www.seedinvest.com/hypersciences.inc/series.a>. You should read the Offering Circular before making any investment.
- This Company's profile and accompanying offering materials may contain forward-looking statements and information relating to, among other things, the Company, its business plan and strategy, and its industry. These statements reflect management's current views with respect to future events based information currently available and are subject to risks and uncertainties that could cause the Company's actual results to differ materially. Investors are cautioned not to place undue reliance on these forward-looking statements as they are meant for illustrative purposes and they do not represent guarantees of future results, levels of activity, performance, or achievements, all of which cannot be made. Moreover, no person nor any other person or entity assumes responsibility for the accuracy and completeness of forward-looking statements, and is under no duty to update any such statements to conform them to actual results.



**Using hypervelocity technologies,
we are creating better solutions for
drilling, tunneling, energy, and transportation.**

**OIL & GAS DRILLING IS
BIG, EXPENSIVE & SLOW**



**RENEWABLE ENERGY
IS INTERMITTENT, AND ALSO
EXPENSIVE**

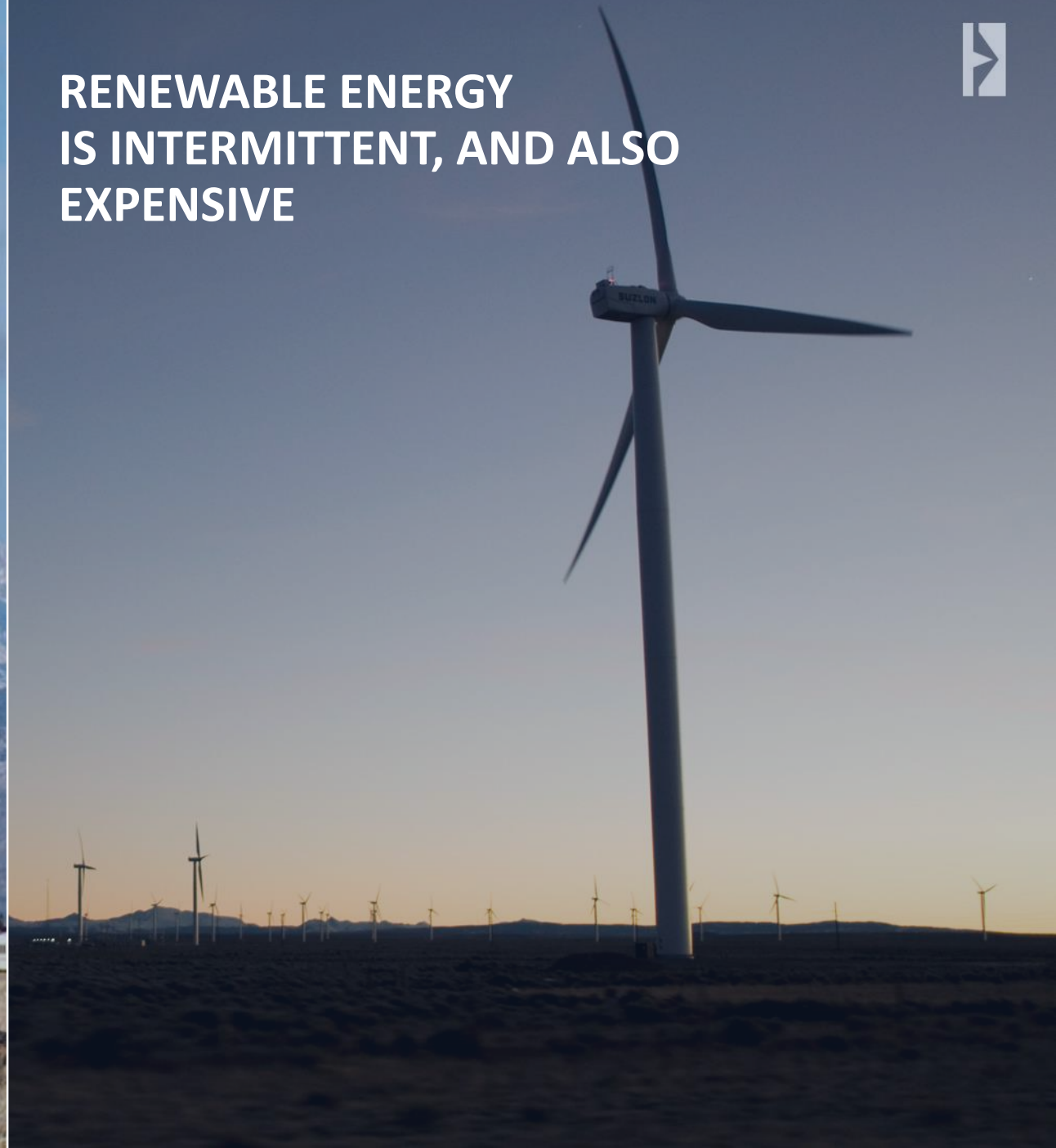

TRAFFIC IS BAD



**TUNNELING IS SLOW,
EXPENSIVE & DANGEROUS**



SOME THINK THAT TRANSPORTATION TUNNELS ARE THE SOLUTION



Industries dependent on old technology – rotational energy – that makes their processes slow, dangerous, and expensive



TUNNELING



ENERGY DRILLING



AEROSPACE

WE PUT
HYPERVELOCITY
TO WORK.



Simple Chemical Energy -> Kinetic Energy -> Work

Industrial. Scalable.
Hyper-projectile technologies.

Introducing HyperCore

HYPERSCIENCES' CORE-RAM PROPULSION SYSTEM

HyperCore technology is the foundation for all of our HyperSciences products. We use low-cost chemical energy to accelerate projectiles to high velocities.

- **In boring/tunneling and mining applications** this meteor-like impact breaks and pulverize hard rock under a wide range of ground conditions.
- **In aerospace applications, our goal is to loft** payloads to extreme altitudes (up to 100km – almost 10 times the operational altitude of commercial jets).

HyperCore



Left and Right



Down

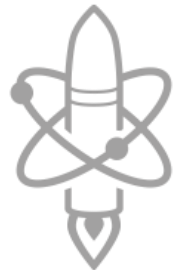

Up



How it works

HYPER TUNNEL BORING & MINING SYSTEM (HTBM)

Our mining and tunneling solution improves performance, eliminates dangerous explosives, and reduces high capital and operating costs over traditional rotary tunneling boring machines and drill and blast methods.

- Our system can be reused unlike most systems that are buried in place upon project completion because of our size and agile steering
- HTBM reduces the need for rotary tunneling equipment, which typically costs greater than \$10M per machine

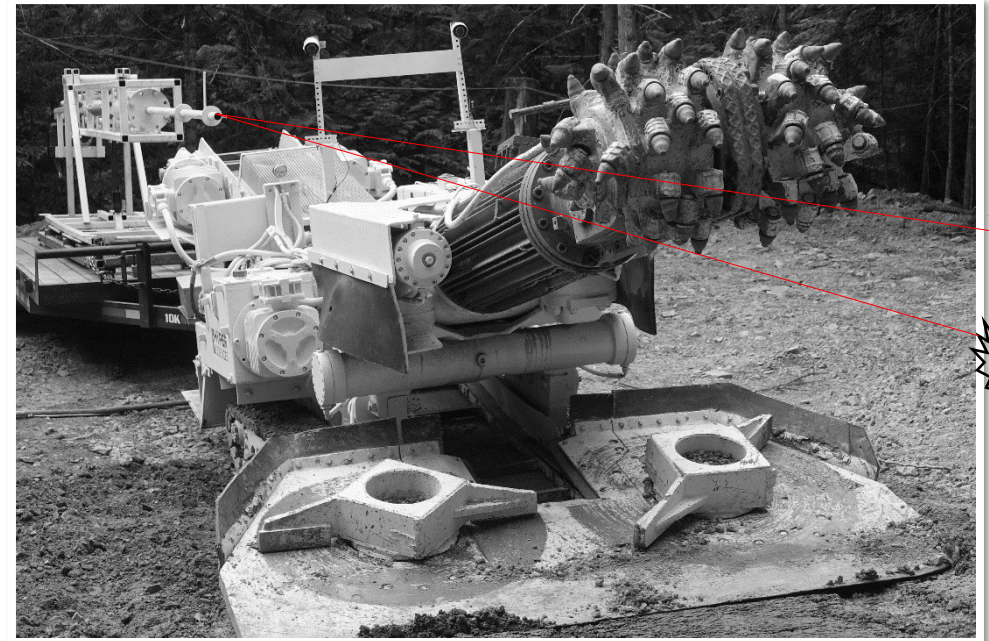

Meteor-like impacts

Using robotic methods and artificial intelligence, this is true digital mining



ENERGY DRILLING

How it works

HYPERDRILL FOR OIL AND GAS AND GEOTHERMAL

Using robotic methods and artificial intelligence, we plan to use our drilling solution to drastically improve performance in regards to speed, accessible depths, and accuracy.

- We have tested our ability to drill holes more quickly and cheaply than other conventional drilling applications
- HyperDrill™ is compatible with existing drilling systems
- Drilling through nearly any ground condition, our impacts are 10-100X the strength of the rock face
- We can 3D map the subsurface and locate energy deposits with ease using our sonar-like process



*Originally funded from concept to reality
with the help of Shell Global*

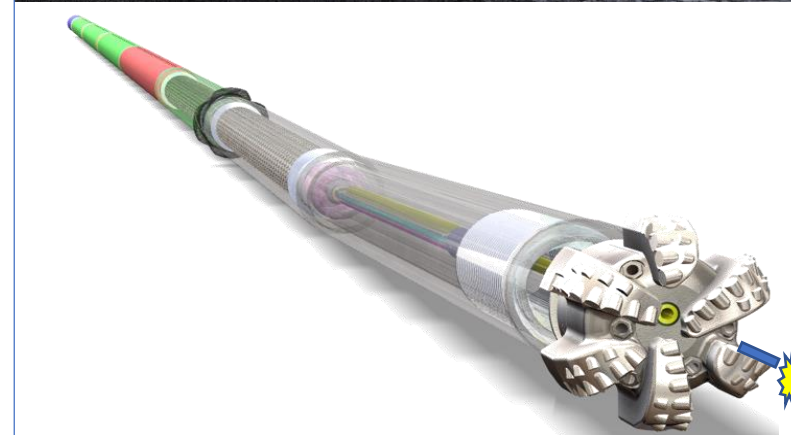
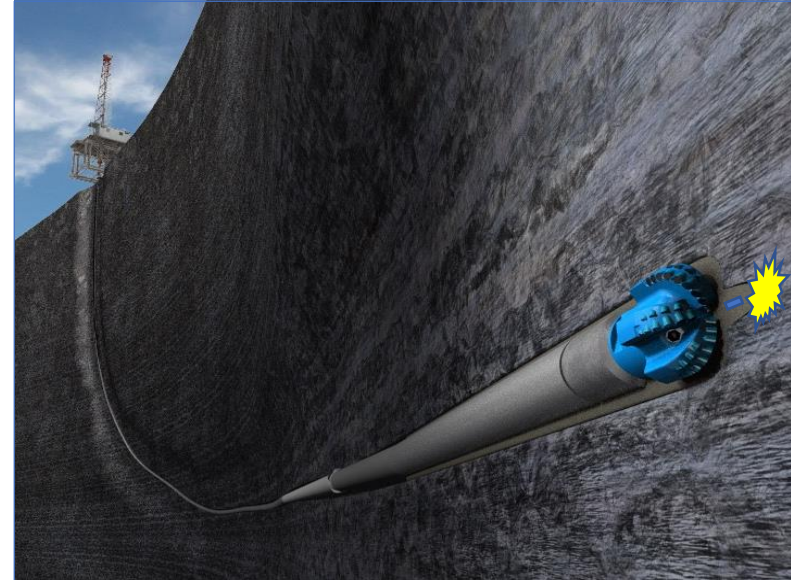



How it works

ENERGY ANYWHERE GEOTHERMAL

Our Geothermal solution leverages the performance benefits of HyperDrill, the ability to reach deep geothermal energy deposits, and our patent-pending thermoelectric power generation technology to provide cost-effective and scalable clean energy.

- HyperDrill has extreme depth reach
- We project that up to 7MW per scalable segment of clean energy can generated back to the main power grid or used for other unique applications
- We believe the physical footprint of the extremely quiet power plants will allow them to be placed nearly anywhere (the size of a small corner store)

The system can be scaled to provide power to businesses

Heat generated from the earth's core

Cap rock

Hot granite rock

Magma (heat source)

20-30km

300°C

Injection well

Production well

Reservoir

Power plant & Heat exchanger

A clean power plant is right below everyone's feet, we just need to tap it!

TEG

THERMAL-ELECTRIC GENERATORS

Video at www.hypersciences.com



The leadership team

EXPERIENCED LEADERSHIP TEAM WITH PROVEN TRACK RECORD



Mark Russell is the founder and CEO of HyperSciences. Mark has a Masters from Stanford in Aero/Astro Engineering, is a former lead engineer and manager for Jeff Bezos's Blue Origin, and has a long history of family and public mining company development and operations for some of the world's largest mining projects. Mark provides both the vision and technical expertise to lead the world's first company focused on hypervelocity applications.



Hossam Elbadway is a technical and business advisor to HyperSciences. He was a Senior Operating Partner at Lime Rock Partners and former CEO of Tercel Oilfield Products, that he sold in May 2016. Prior to serving in these roles, Hossam spent nearly 17 years at Schlumberger, most recently as Vice President of Manufacturing. He currently serves on the board of directors of GEODynamics, and TGT Oil and Gas Services.



Mike McSherry is a board member and senior advisor for HyperSciences. Mike is a serial entrepreneur; he is the current CEO and founder of Xealth, a healthcare tech company. He is also the former CEO of SWYPE (mobile app), and the co-founder of Boost Mobile.

Funding:

RAISING UP TO \$10M THROUGH A REG A+ OFFERING ON SEEDINVEST

\$3M closed (Oct 2018) \$7M remains open/active

Traction thus far:

- \$1M+ funded by Shell Global over three-phase HyperDrill Development
- \$3M in convertible notes (2015-2017) used to develop technology and equipment
- 31 global patents at various stages
 - 3 Issued
 - 2 Allowed
 - 26 Pending

Planned use of proceeds for the SeedInvest round*:

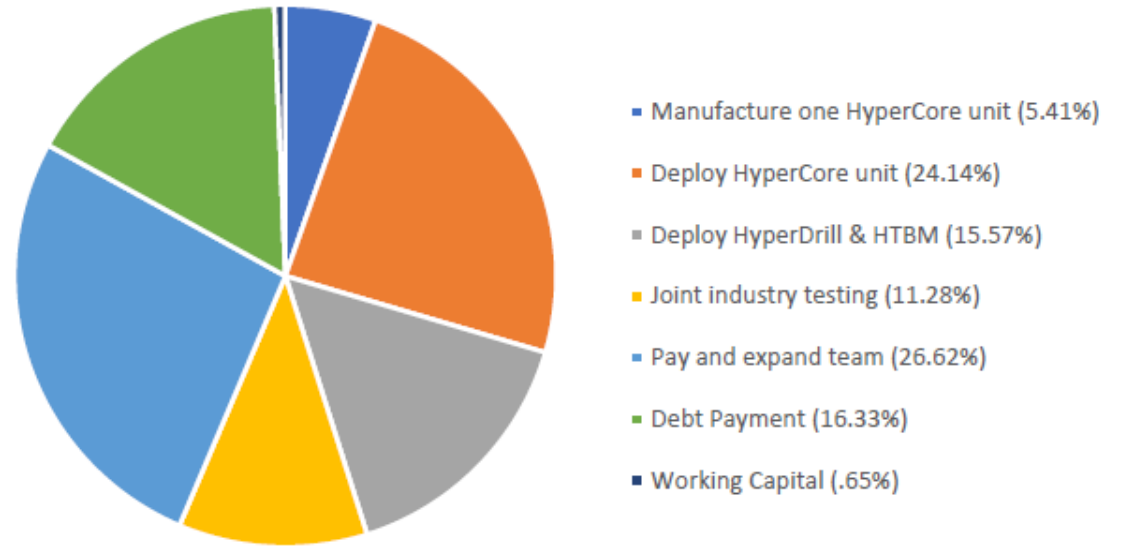

*Assuming minimum \$2.5M raise

- Shell Game Changer



2.5 yr Funded

- Proven Technology

High Pressure Demo Tests

Fiber Optic Acoustic “Tomography”

100’s tunneling field tests

Steerable

- Independent econ analysis:

\$15.5 Billion dollar value in drilling

\$100’s M + annual revenues

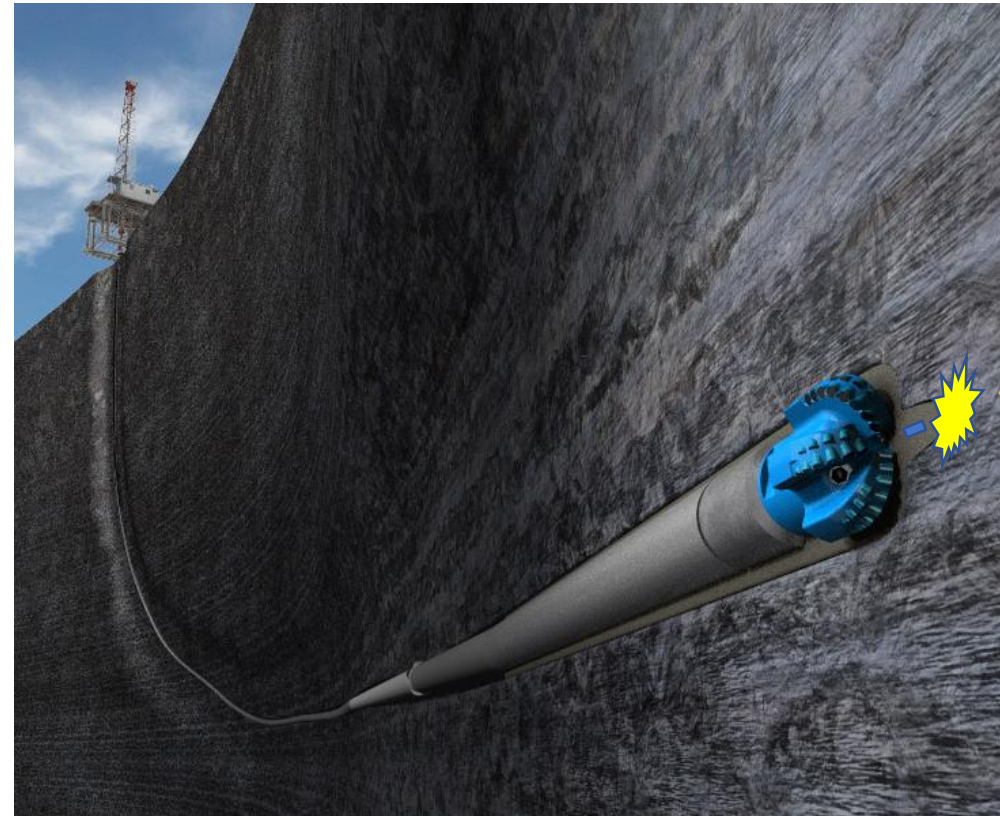

Augmented HyperDrill™: Guaranteed performance

Key Advantages:

- Lower Bit Count & Trips
- Save up to 50% Rig Days/Cost
- Complete compatibility
- Fast !

Key Use Cases:

- Chert & Variable rock
- Deep
- Hard Rock

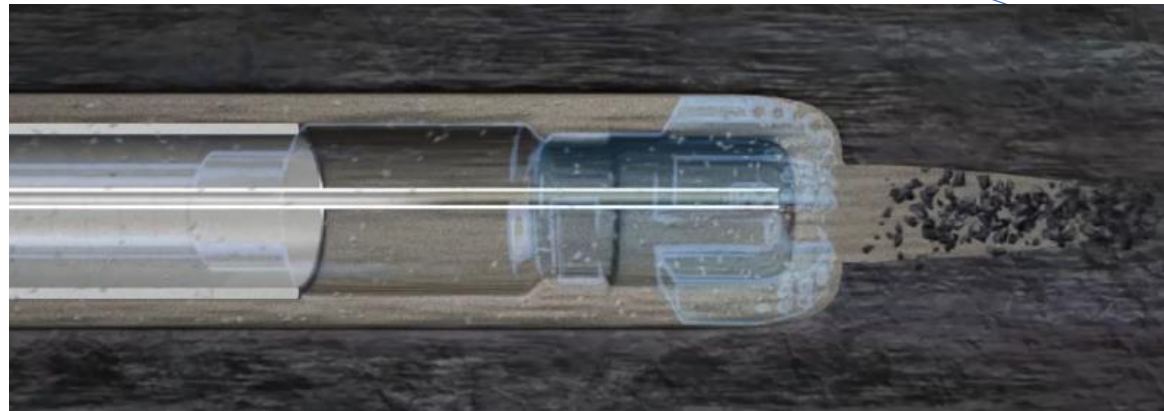
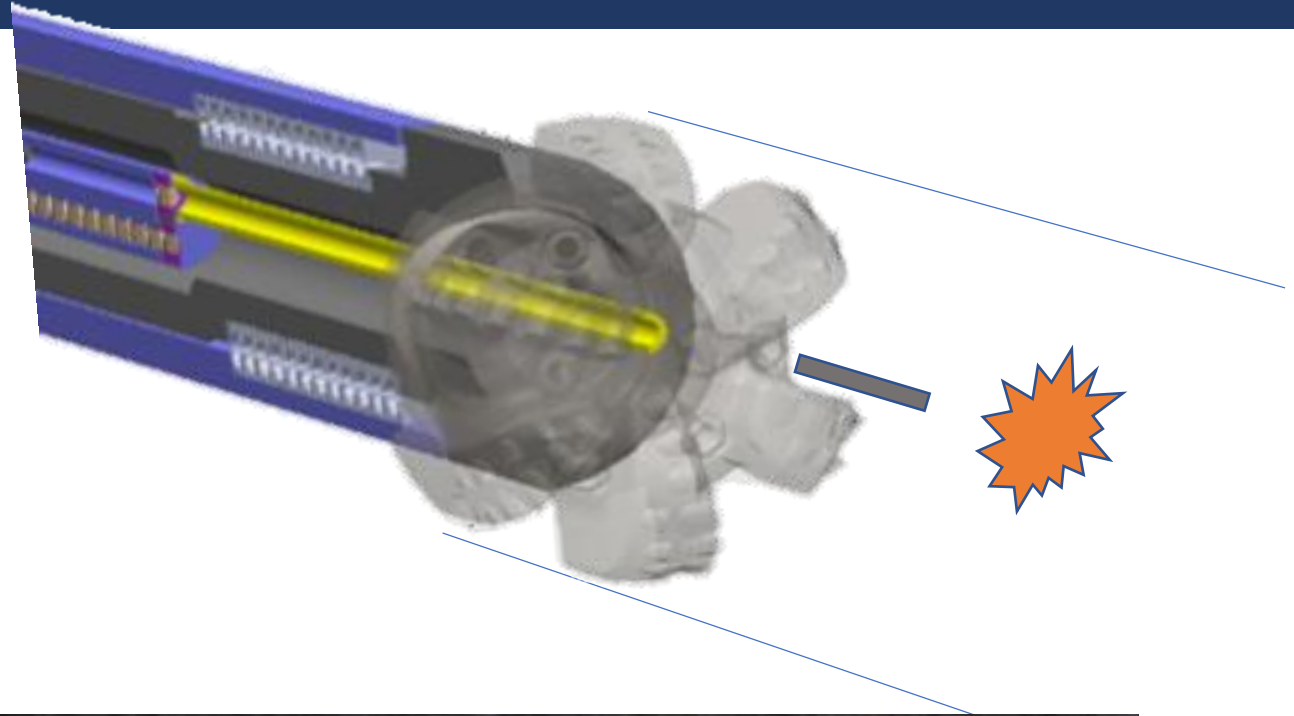

HyperDrill



Augmented HyperDrill



Phase 1, Vertical, Shallow Hard Rock

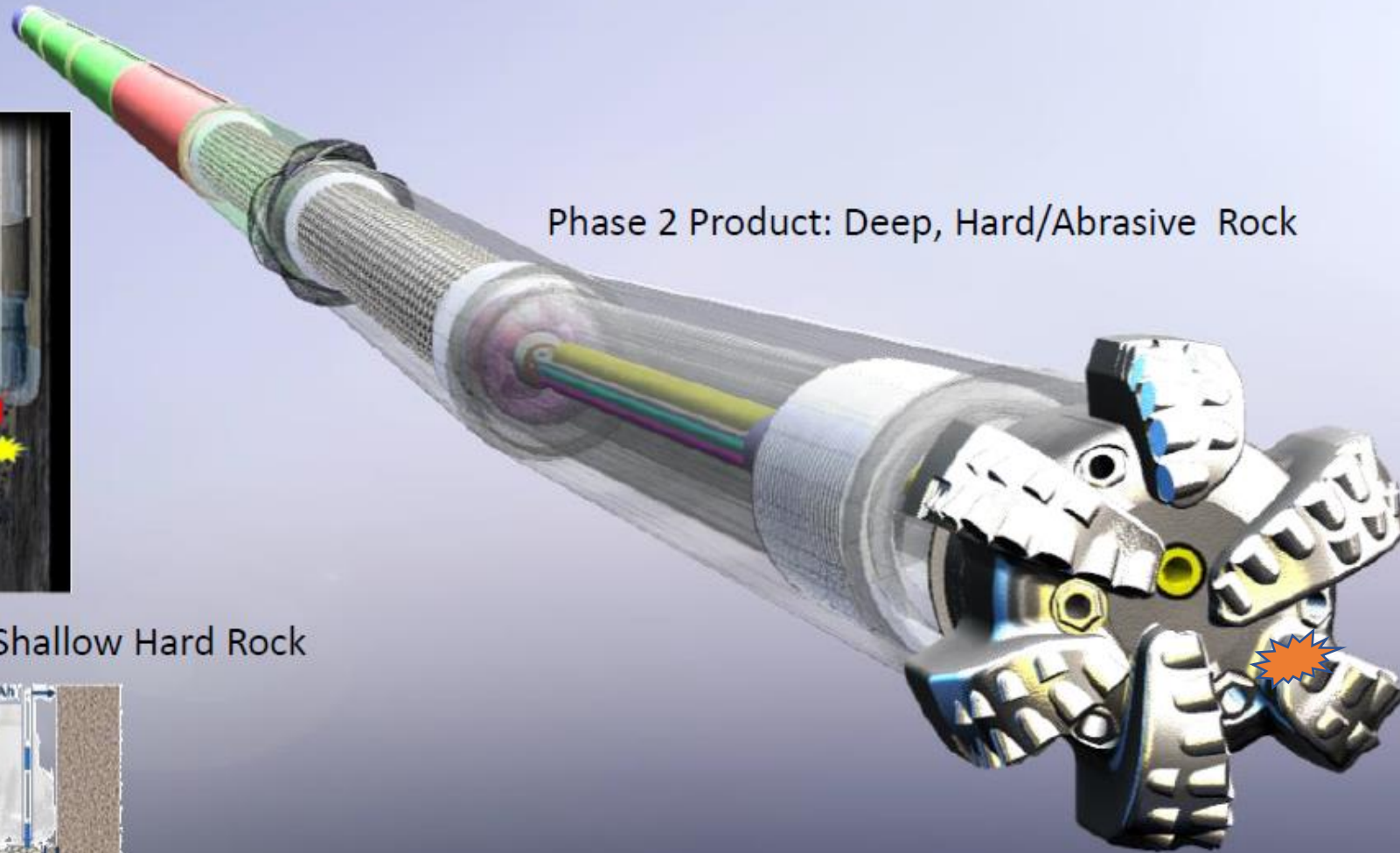
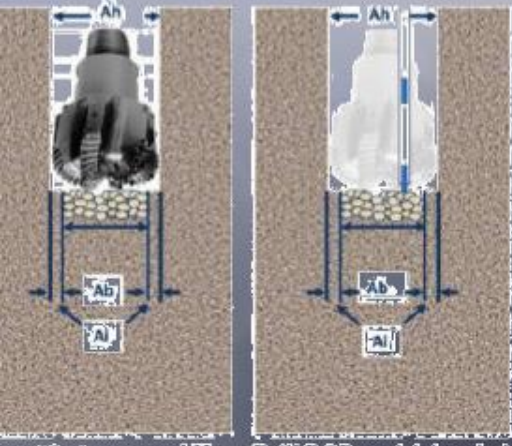

Phase 2 Product: Deep, Hard/Abrasive Rock



Phase 1

Aug. HyperDrill Technology Overview

Driver Tech

Diesel/air HyperCore is integrated in the BHA, Similar propellants as diesel engine

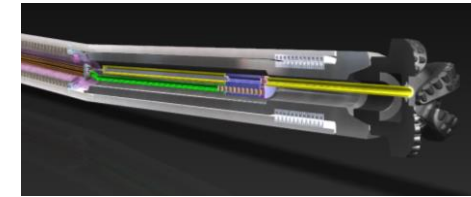

Driven Tech

Composite projectile is designed for high density to maximize dynamic pressure but will erode at impact.



Performance

Projectile impact creates crater, weakens rock, and creates fractures, improving ROP by 5-10x especially in hard rock and high pressure conditions



HyperDrill™: Quantum Leap in Depth, Time & Cost.

Step-function improvement on Existing Rotary Tech



Proven.

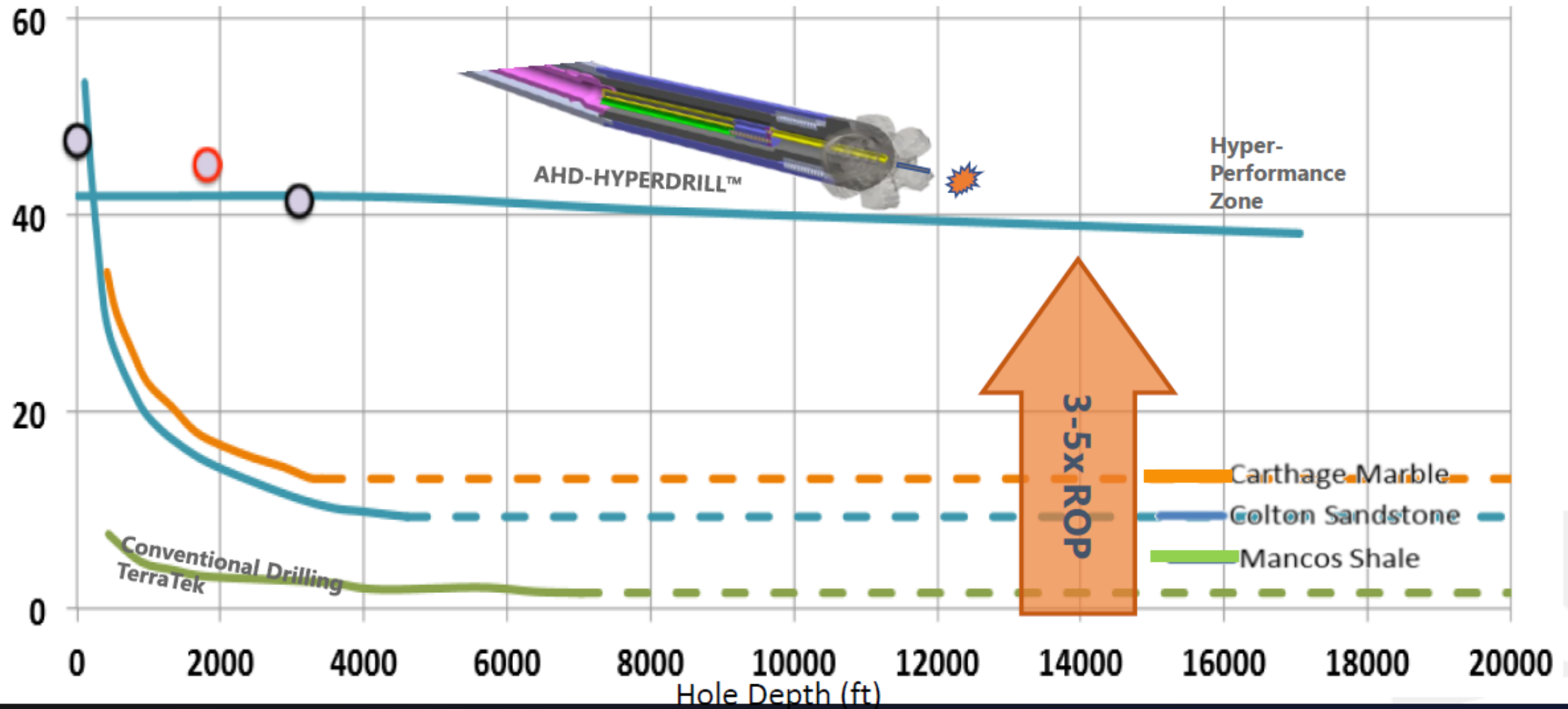

HOW: Focused Energy: Short, Extreme Pressure Impacts

10-100x rock strength = New way to break rock

Generate pressures that are order of magnitude greater than rock strength

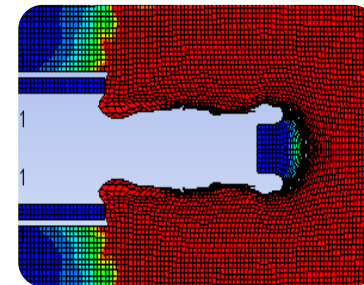
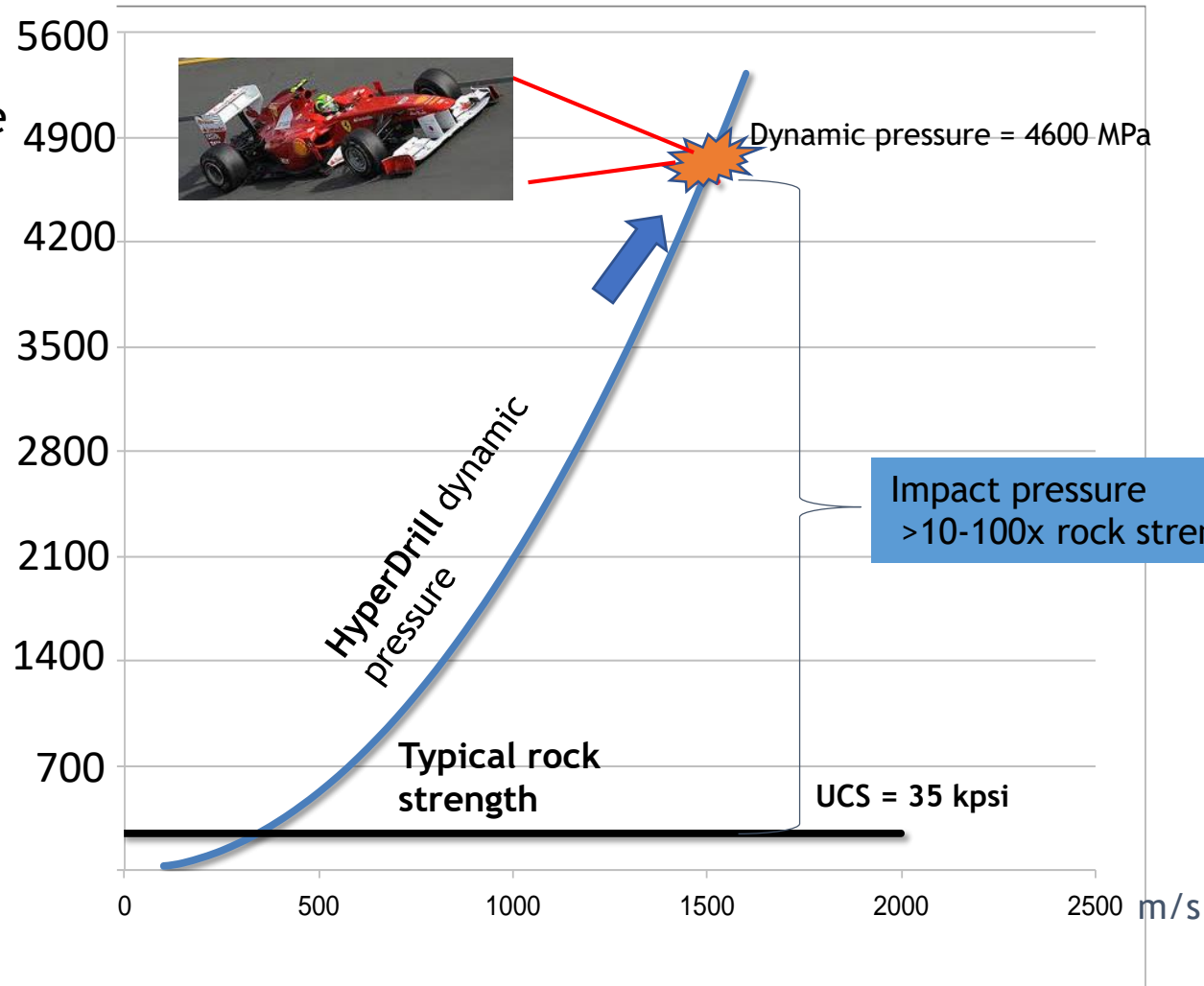

World's fastest commercial projectile technology: Mach 4.5+

HyperDrill Ai™ continuous microseismic Fast Drilling & Intelligent Completions

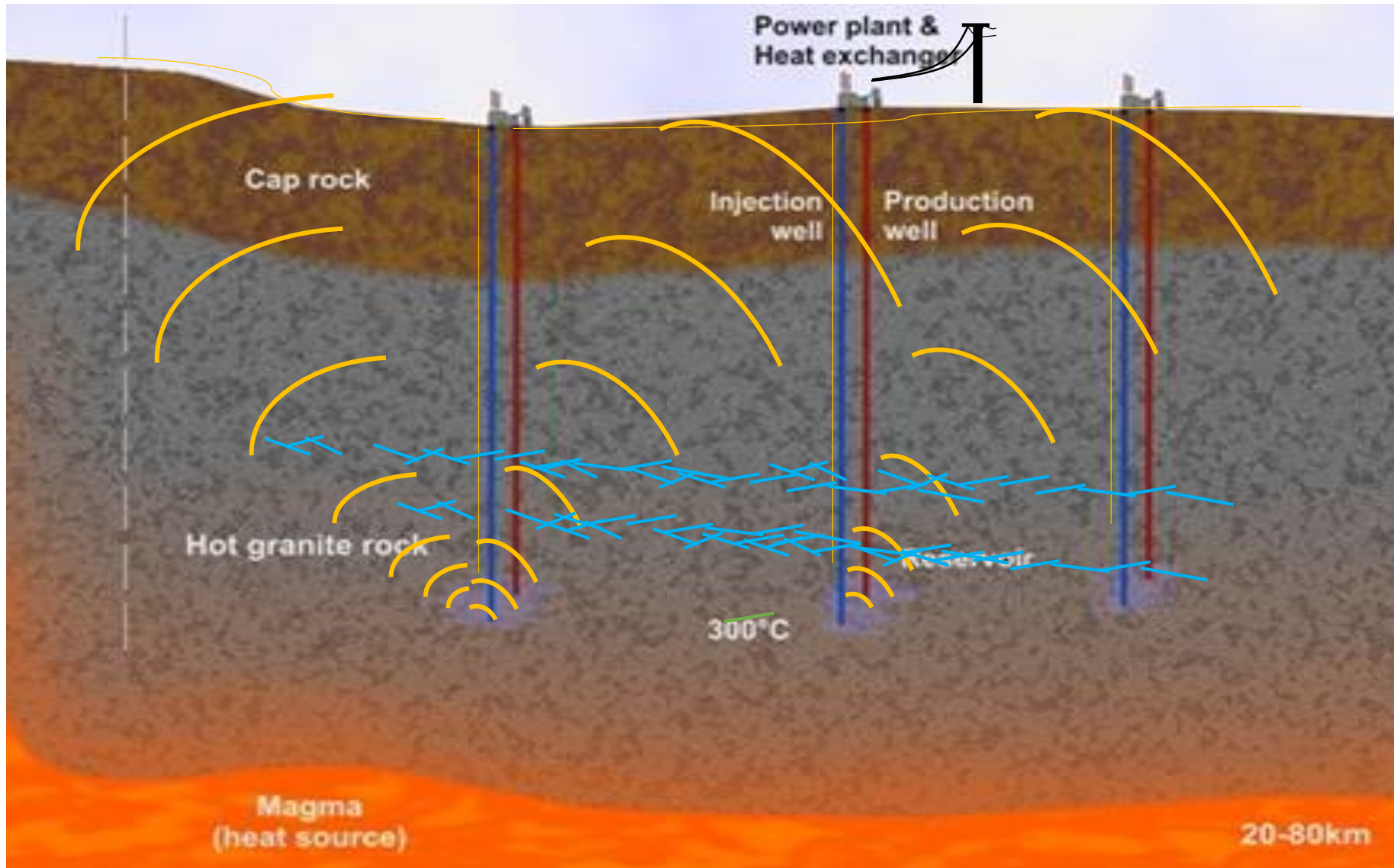

JIP Phase 1

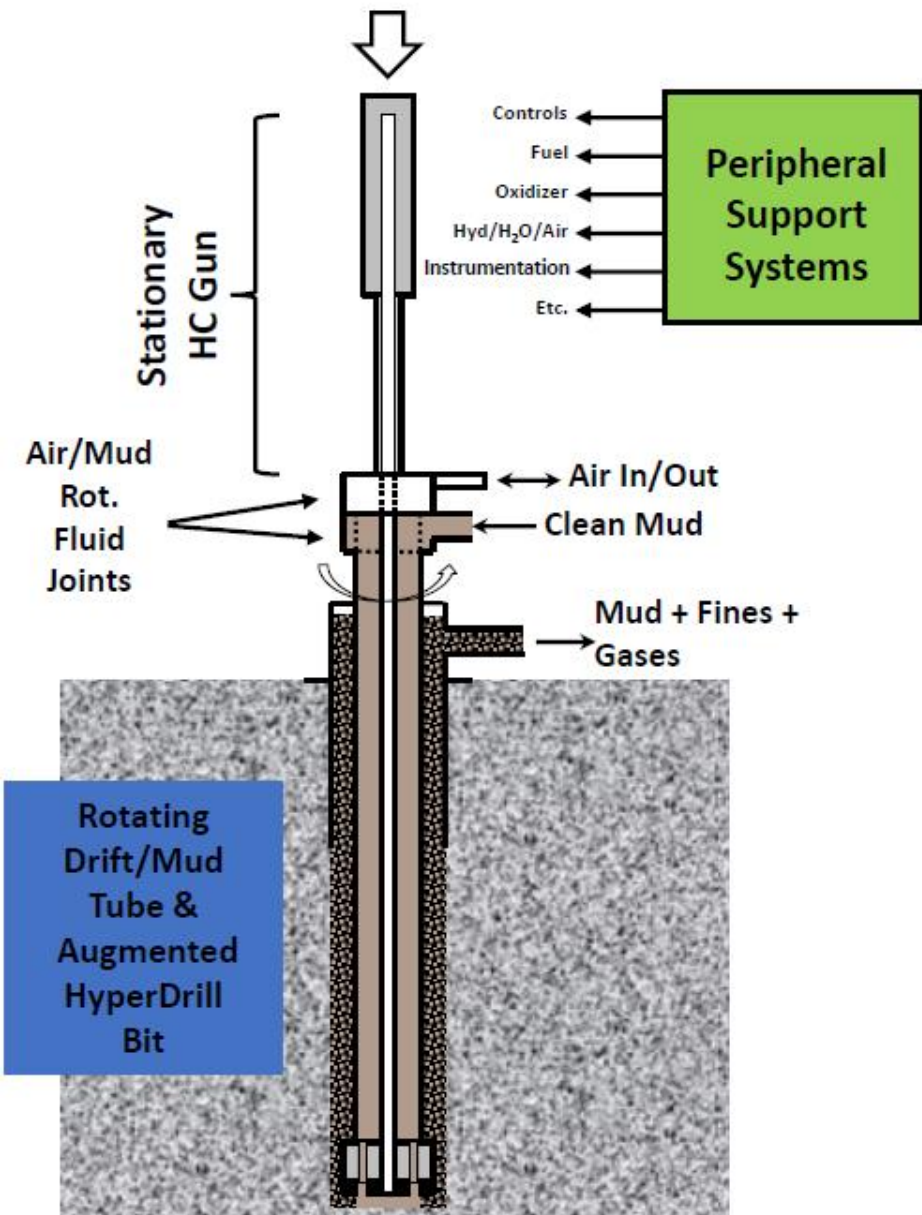

High Level Requirements

- >3x ROP Improvement Over Conventional By Phase II
- Cuttings Removal Via Mud
- Shoot Through Mud At Bit
- All Major Systems Above Surface
- Stationary Firing Gun + Rotate Bit While Firing
- Drift Tube To Bottom
- No Combustible Gun Exhaust Gases
- Drill 1000 ft @ 100-300 ft depth
- Utilize The HC 1.0 Projectile Launcher
- Shaped Projectiles
- Investigate Effects Of Projectiles On Bit Life

Seeking **JIP Partners Non-Equity**

Non-equity Joint Industry Project Partners

- HyperDrill Field Trials
- **Phase 1:** 8-12" Hole 1000 ft (Shallow)
 - \$250k/partner
- **Phase 2:** 8-12" Hole 2000 ft section (Deep 10,000 ft appx)
 - \$1M/partner



Hypervelocity.
A revolutionary
technology platform

Disruptive Innovation

Paradigm shift: Pulverize hard rock. New Materials



Minimum Viable Product Downhole Tool Design

Tool Features:

- 3-5x ROP Improvement
- Drop-in compatible with existing drilling technology
- Augmented HyperDrill – HyperCore gun integrated into rotating drill bit
- BHA features
 - Bent sub steering to 15 deg/100 ft

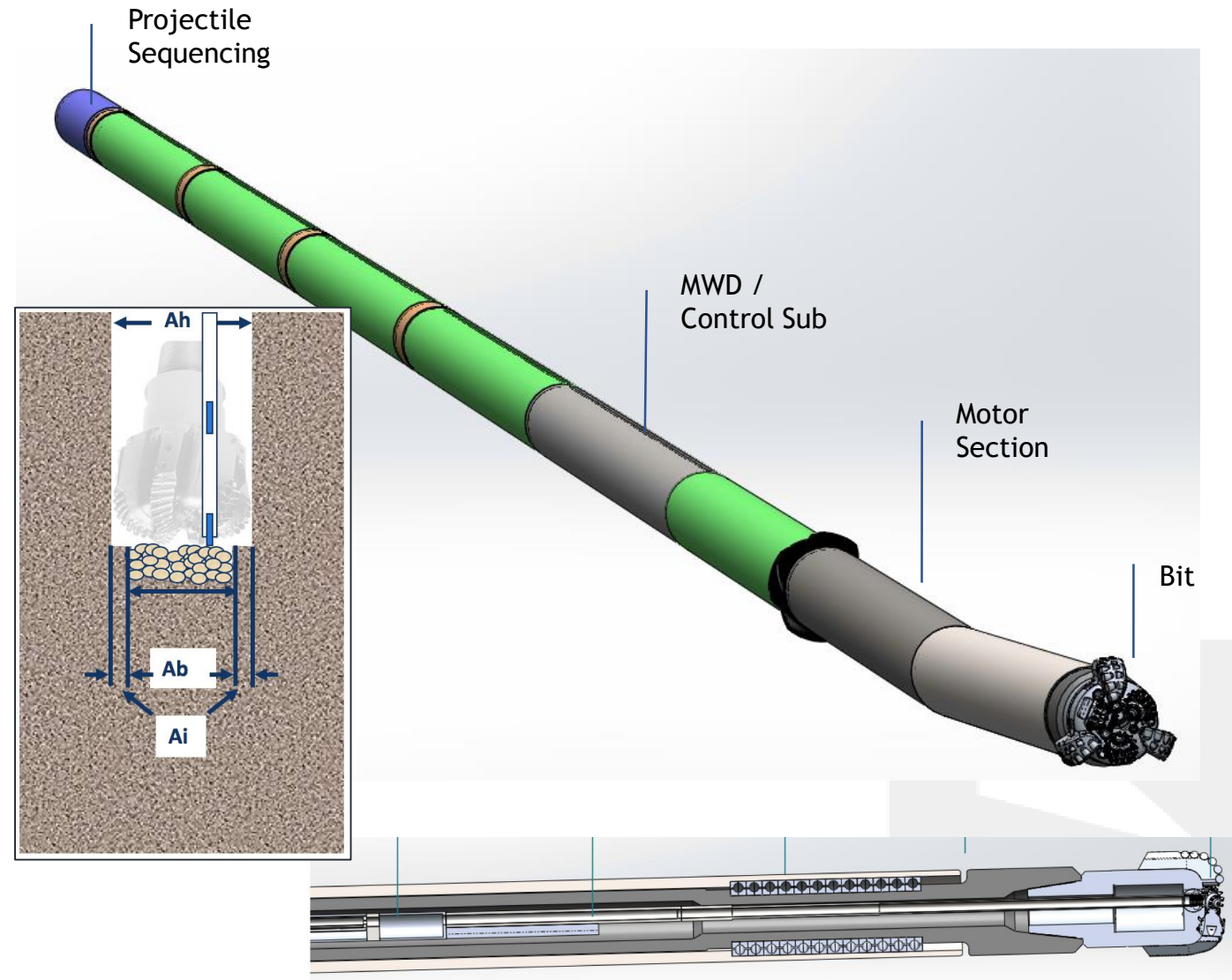

O&G Drill a Well on Paper Summary: \$1- \$4M per well net saved w/ Aug HyperDrill

- Europe: **\$4.6MM (38%** of Combined Sections Drilling Costs) per well **net** savings to operator
 - Expected 10-12 well program = \$50MM savings
- Oman: **\$1.35MM (47%** of Combined Section Drilling Costs) per well **net** savings to operator
 - Expected 60-100 well program = \$105MM savings
- **Performed economic analysis for another Major IOC company** – confirms our results.

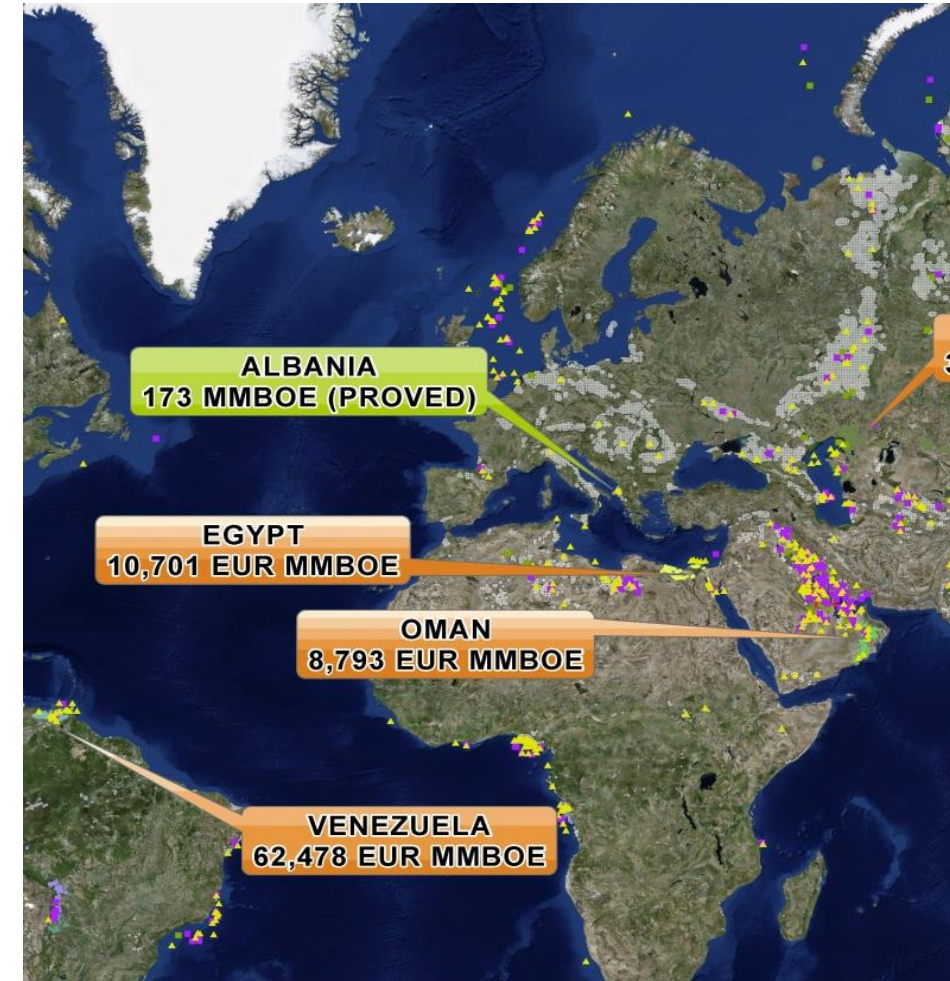

Damage Zones Details –Computational MSE ROP Models

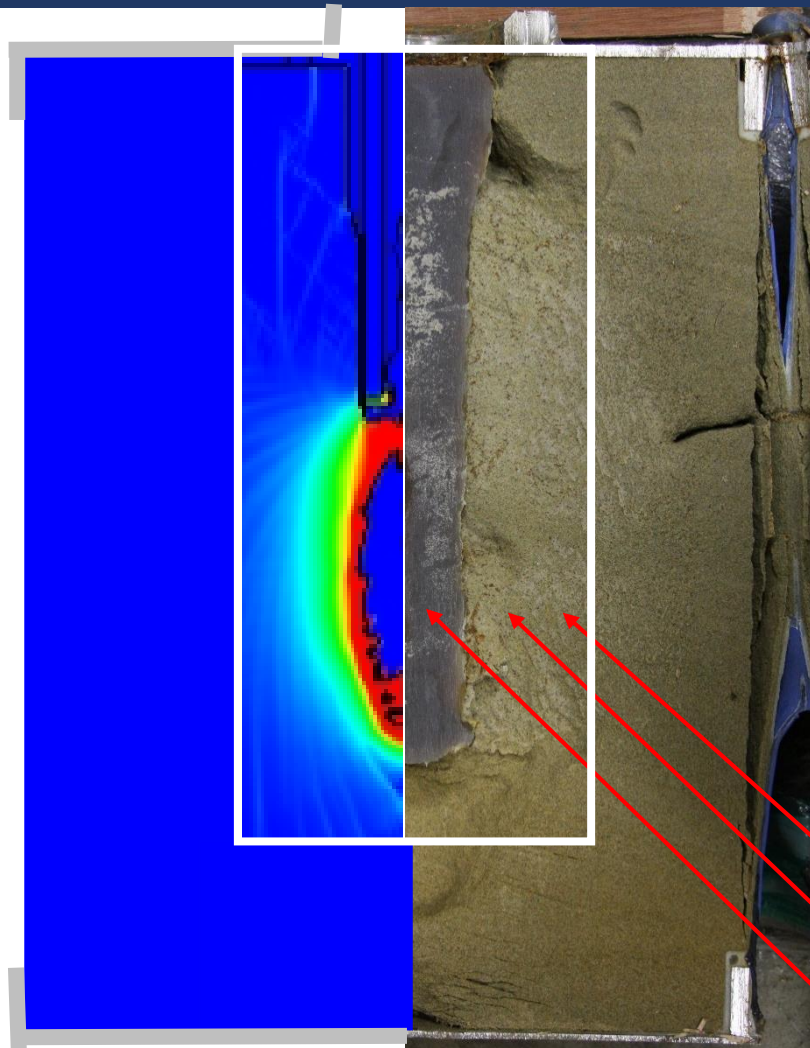

CTH Model

HSI/SWRI Test

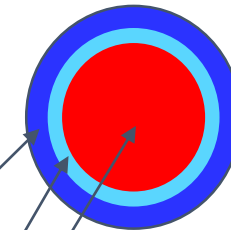
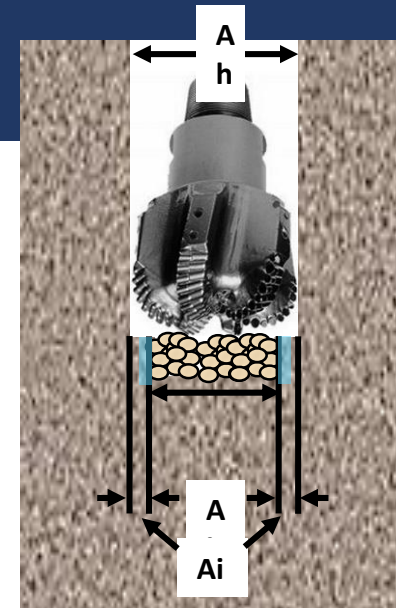

There are three zones in the hole bottom post-shot:

1. Intact rock
2. High porosity (weakened) rock
3. Crater

O&G Drill a Well on Paper Summary: \$1- \$4M per well net saved w/ HyperDrill

- Shell Project 1: > **\$4 MM**
 - (**38%** of Combined Sections Drilling Costs) per well **net** savings to operator
- Shell Project 2: > **\$1.5MM**
 - (**47%** of Combined Section Drilling Costs) per well **net** savings to operator
- **Performed economic analysis for another Major IOC company – confirms our results.**





Note that this is a small but indicative fraction of the hundreds of thousands of newly drilled wells added every decade

Value:
\$15+ Billion

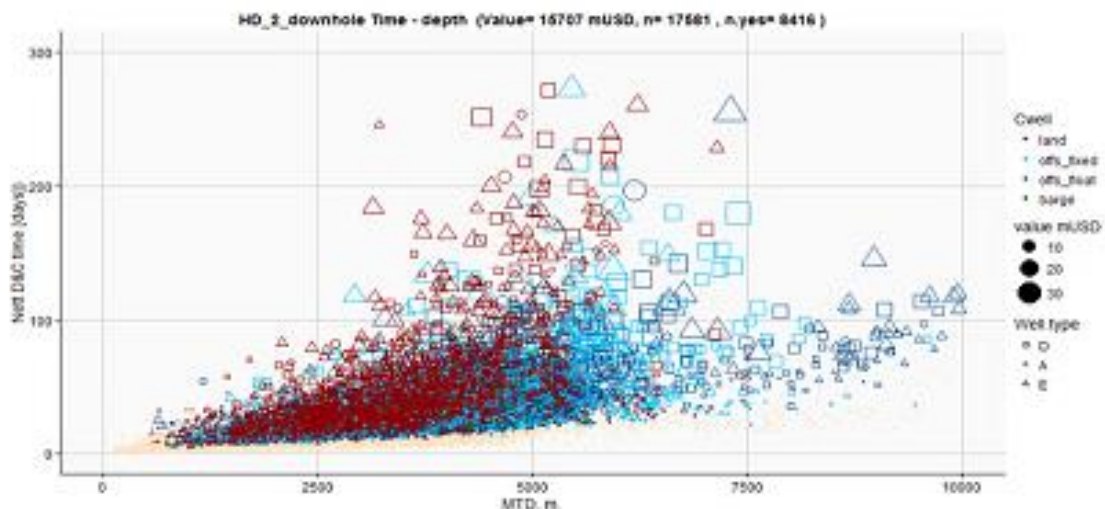

- Total value of base-line HyperDrill 1.0 design over the 10 year dataset is 15.7 billion USD, averaging 10% saving on dry hole cost on 8416 wells where the Downhole HyperDrill was used
- Value now more 20/30/50 for land/fixed/floating pushing value towards the high-end offshore floating installations.

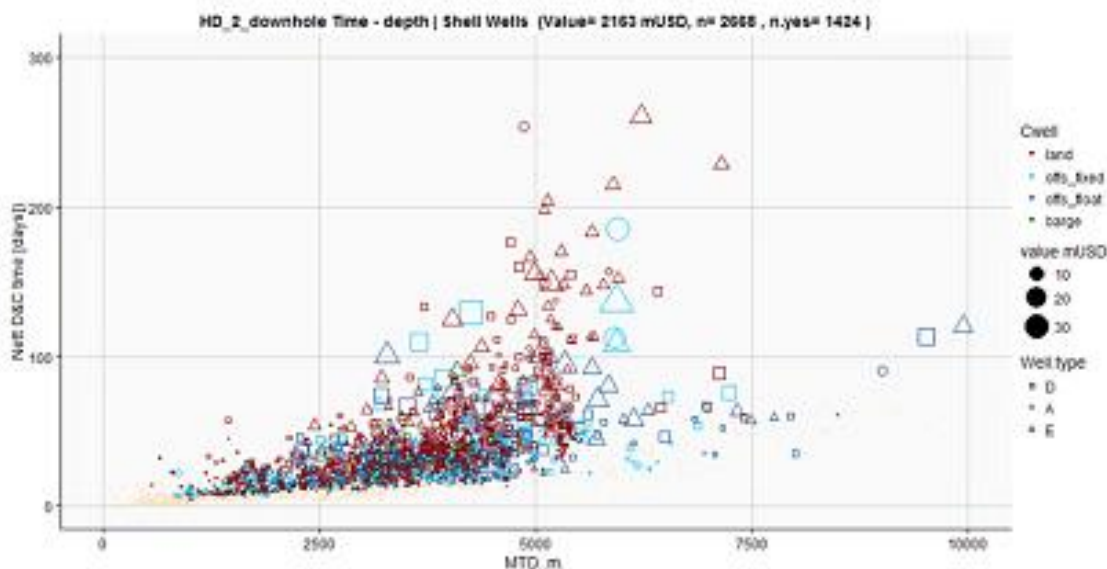

- Value of application to Shell and ex-BG portfolios approx 2.2 billion USD.
- Does not include non-operated wells-most

- Technology basis mature and demonstrated
- MVP design complete & vetted by Shell and another Major
 - No Technical show stoppers
 - Risks identified and plan to test/mitigate identified
 - Series A ask focused on proof well demo
- DWOP Oil & Gas shows game Changing economics for operator
 - Europe: \$4.6MM (38% of Combined Sections Drilling Costs) per well net savings to operator
 - Expected 10-12 well program = \$50MM savings
 - Oman: \$1.35MM (47% of Combined Section Drilling Costs) per well net savings to operator
 - Expected 60-100 well program = \$105MM savings
- Large opportunity Deep / Hard Rock
 - \$15 bn (10 year)

- 981m interval
- 6 bits
 - 4 PDC
 - 2 Impregs
- ROP = 3.2 m/hr
 - ~300 drilling hours
- ~18 days drilling + tripping
- UCS 35 – 65 ksi
- Temp 320 – 356°F
- MW = 14.1 – 14.4 ppg (OBM)
- Data provided by Shell via Email
 - K5 Bit Record

DWOP Oman 8-3/8" Hole Section HyperDrill 3-5x improvement

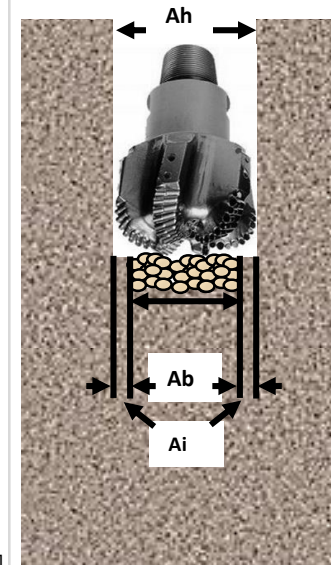
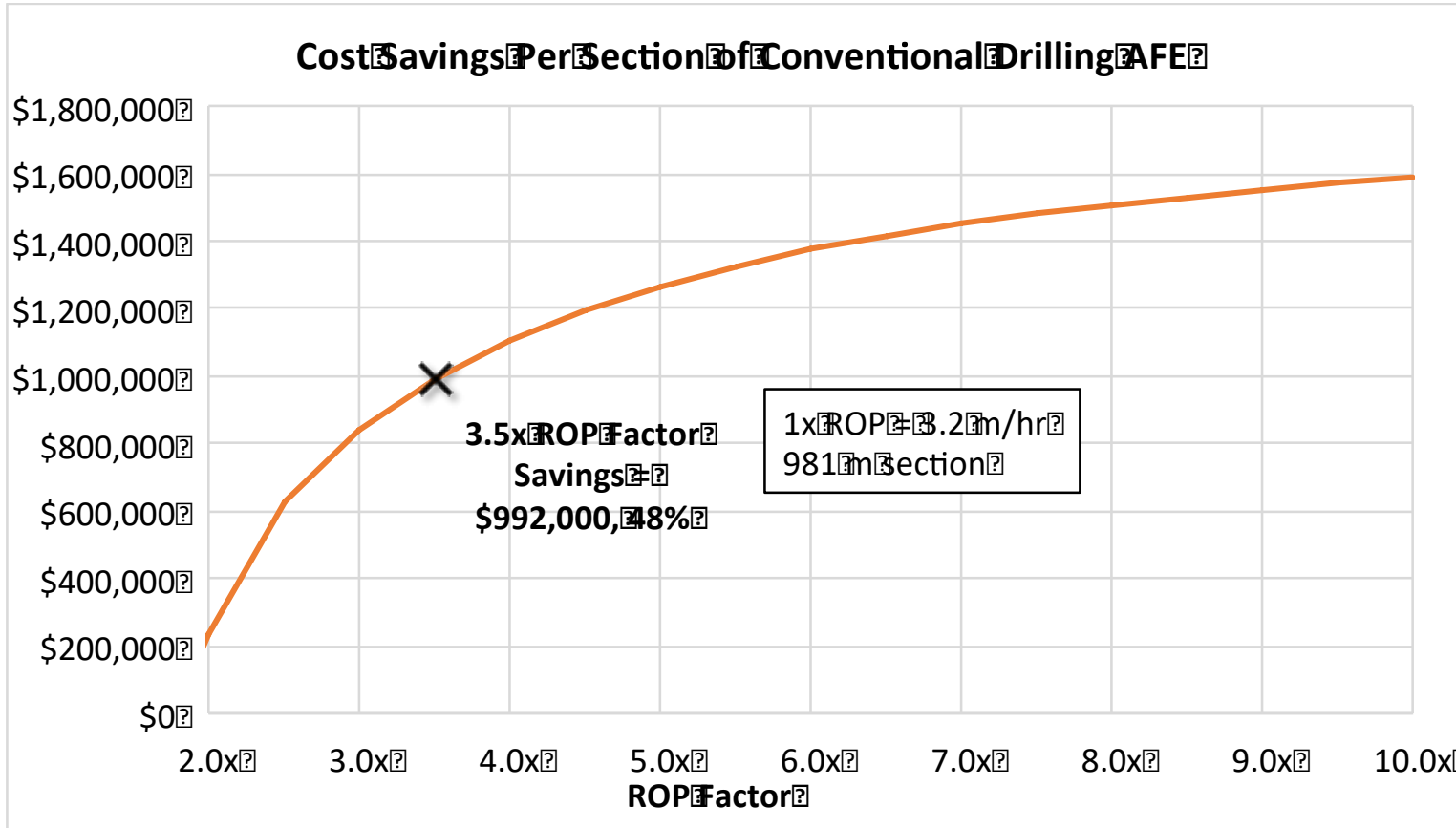

HyperDrill™ 8-1500-S
1500m/s
3", 27 gram darts
0.7" ID Barrel
Steering

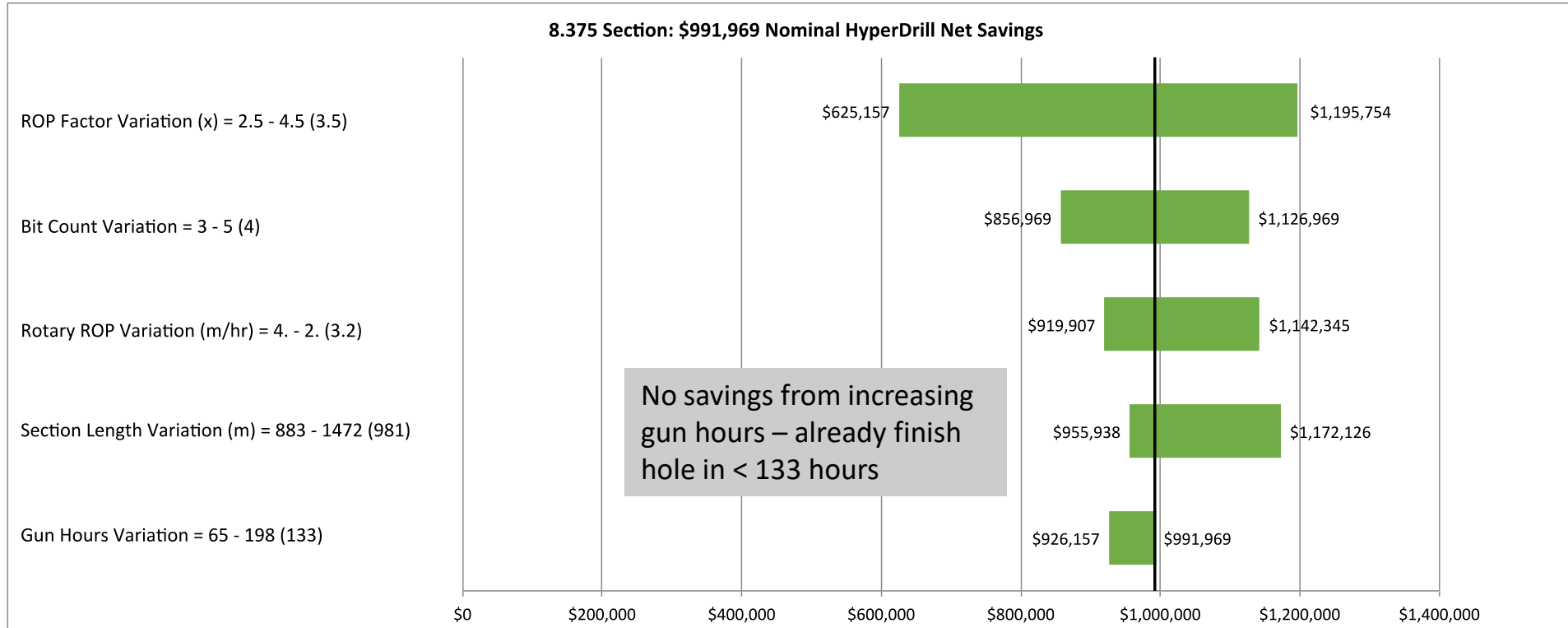

Nominal Net Savings: \$992,000

Minimum Net Savings: \$625,000 (ROP Factor Variation)

Maximum Net Savings: \$1,200,000 (ROP Factor Variation)

Summary: Slower conventional drilling and higher HD Performance = higher potential HyperDrill savings

DWOP Oman HyperDrill™ improvement

8.375" Gross Savings - \$1,40,000 - \$2,140,000 /section

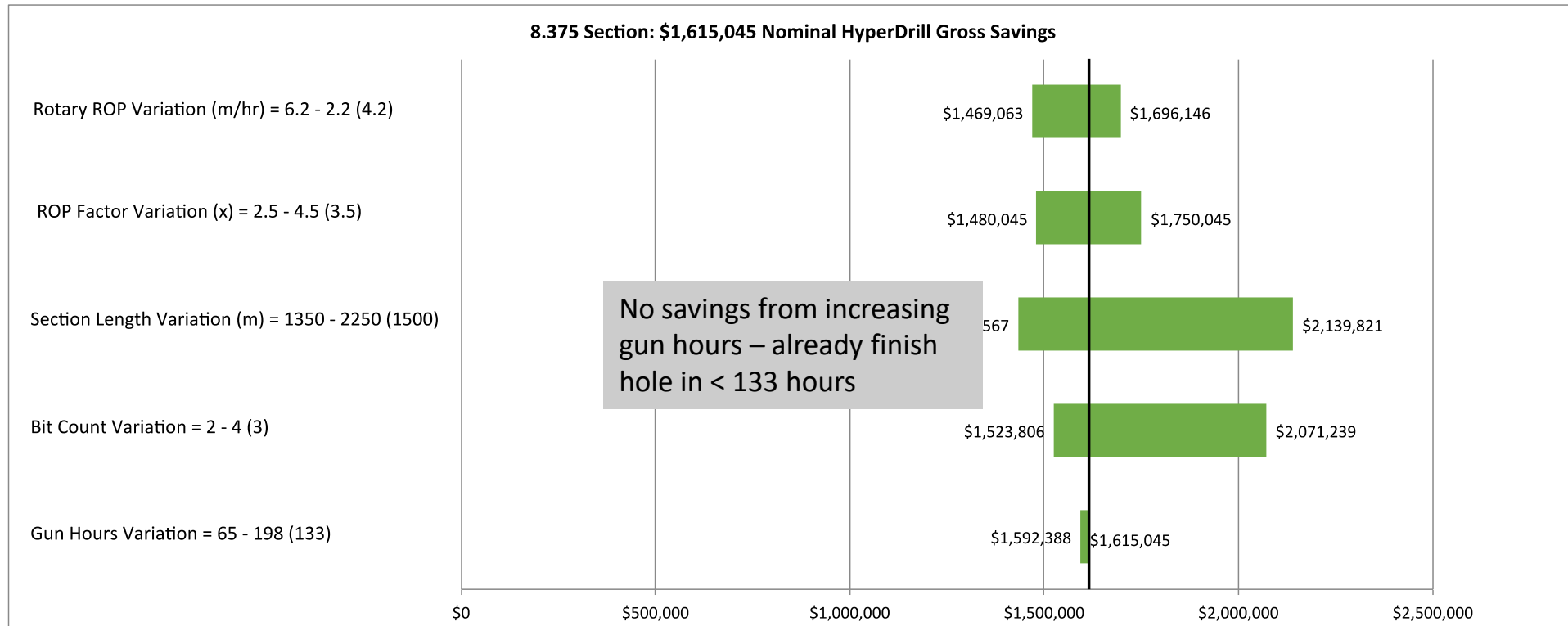

Nominal Gross Savings: \$1,615,000

Minimum Gross Savings: \$1,430,000 (Rotary ROP Variation)

Maximum Gross Savings: \$2,140,000 (Rotary ROP Variation)

Summary: Slower conventional drilling = higher potential HyperDrill savings

DWOP Oman HyperDrill™ improvement 8.375" Section – Net Savings, Nearly Every Scenario

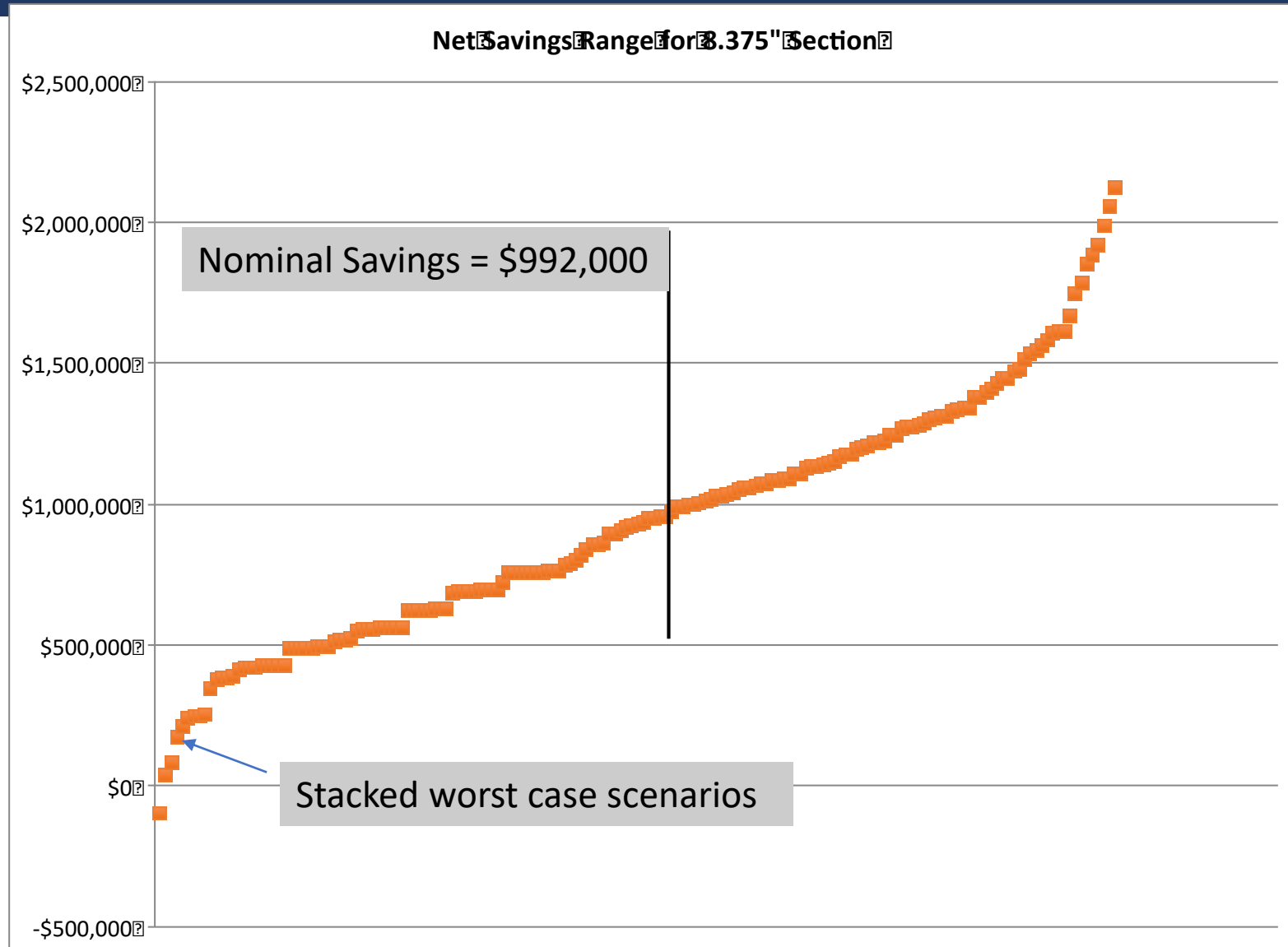

DWOP Oman HyperDrill™ improvement Days vs. Depth – days saved

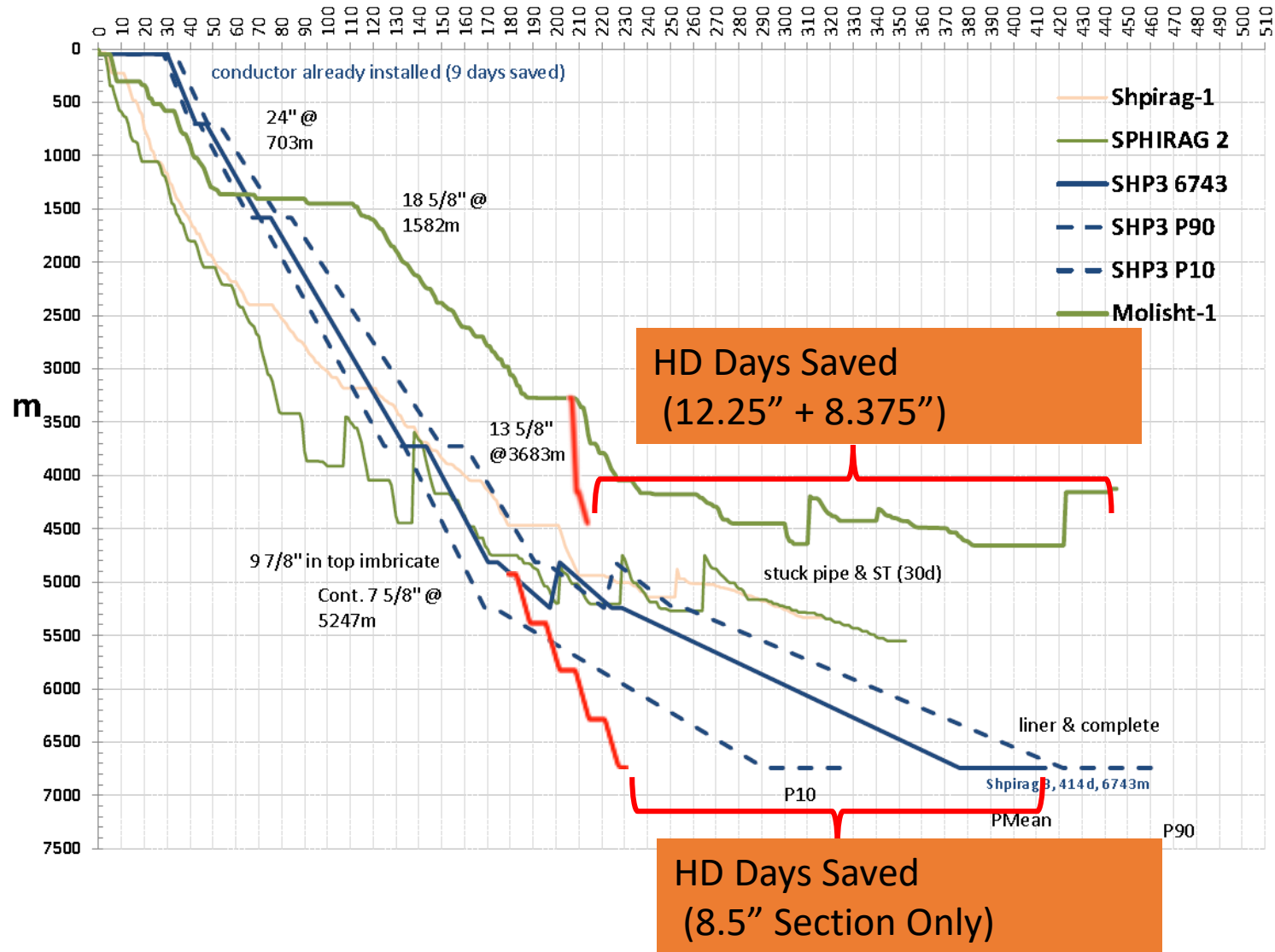

Seeking **JIP Partners Non-Equity**

Non-equity Joint Industry Project Partners

Hypervelocity.
A revolutionary
technology platform



- HyperDrill Field Trials
- **Phase 1:** 8-12" Hole 1000 ft (Shallow) \$250k/partner
- **Phase 2:** 8-12" Hole 2000 ft (Deep 10,000 ft appx) \$1M/partner

Disruptive Innovation

Paradigm shift: Pulverize hard rock. New Materials



- Technology basis mature and demonstrated
- MVP design complete & vetted by Shell and another Major
 - No Technical show stoppers
 - Risks identified and plan to test/mitigate identified
 - Series A ask focused on proof well demo
- DWOP Oil & Gas shows game Changing economics for operator
- Large opportunity Deep / Hard Rock
- JOIN OUR JOINT INDUSTRY PROJECT

Seeking Series A Investment & JIP Partnership

DISRUPTIVE INNOVATION
MULTIPLE INDUSTRIES
BILLION \$ MARKETS

TECHNOLOGY DEMONSTRATION PLAN:

- • *HYPERDRILL TRIALS*
- *CUSTOMER ACQUISITION / PARTNERSHIPS*

CONTACT INFORMATION:

FOR FURTHER INFORMATION,:

Mark Russell, CEO

+1 (509) 994.8577

mark@hypersciences.com



This *is* rocket science.



Backup Technical information

HyperDrill™: Quantum Leap in Depth, Time & Cost.

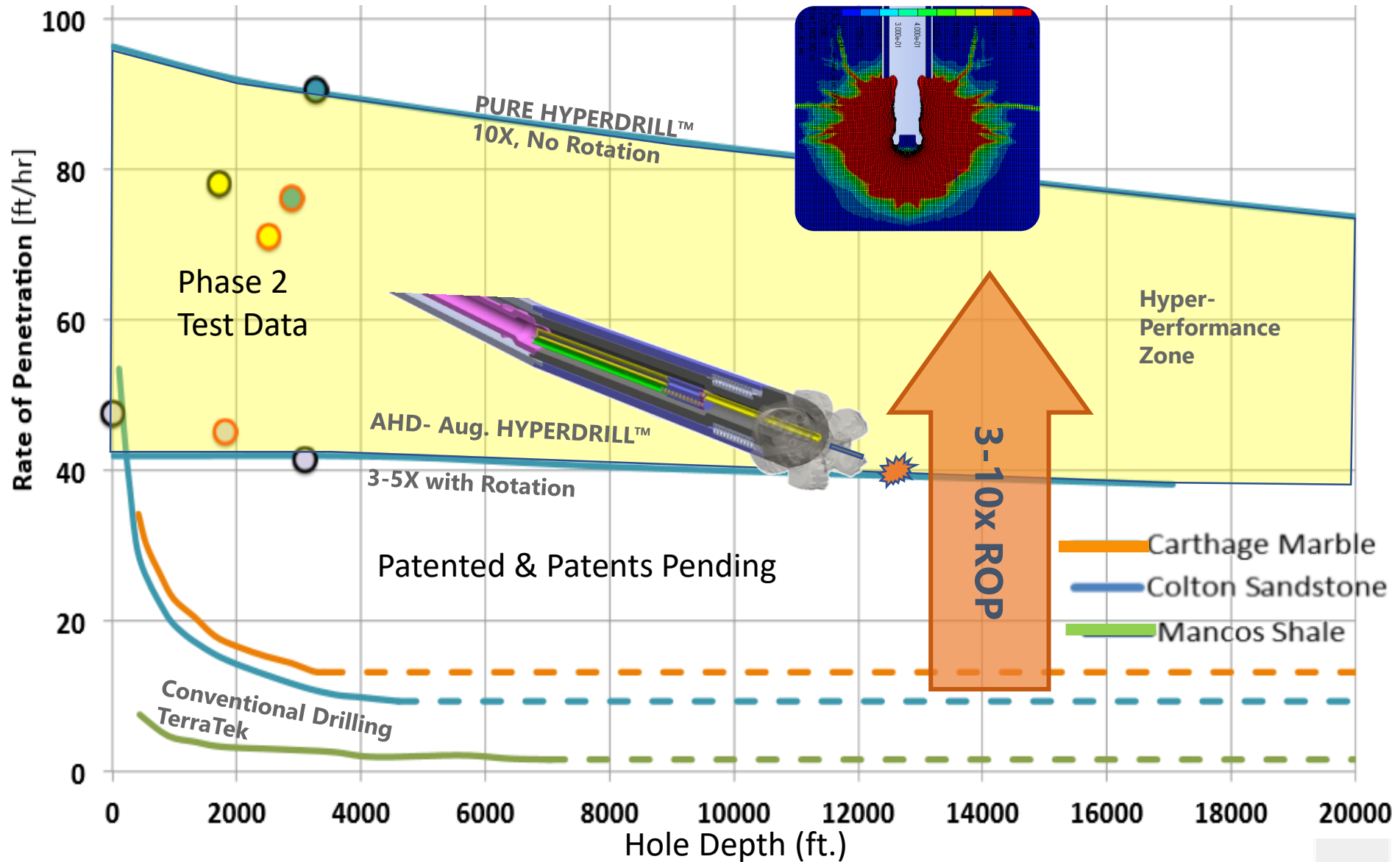

Proven.

Business model

EQUIPMENT-AS-A-SERVICE – DRILLING, MINING, AND TUNNELING

Much like razor for razorblades, or ink for printers, HyperSciences generates some of its recurring revenue from the sale of consumables.

- HyperSciences' equipment is leased
- Consumable projectiles priced at a few dollars per unit
- Generating recurring revenue per machine for drilling and tunneling

Reducing the barrier to entry for a new technology.



AEROSPACE



TUNNELING



ENERGY GENERATION



ENERGY DRILLING

The Physics of Hyper Impact (Mining or Pure HyperDrill)

- **Energy:** $E = \frac{1}{2}MV^2$ (Joules)
~1MJ: 700 grams @ 1650m/s
- **Power:** $P=E/dt$ (Watt)
~350 MW (.003 sec)
- **Impact Pressure** = $\frac{1}{2}\rho V^2$ (Pa) [psi]
~4000 MPa
~ 500 Tonne-Force
- **Break Rock:**
Variable: Mass, Velocity
5X-10 X Faster, 30-80% lower cost

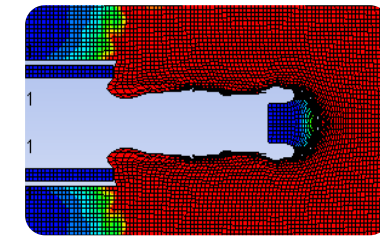

HyperCore

HyperCore – 38mm projectiles

- Simple, Safe, Reliable
- Automated, Continuous
- Dual Use
 - Mining/Tunneling
 - Drilling 38 mm projectiles
 - Up to 12.25" JIP hole demo

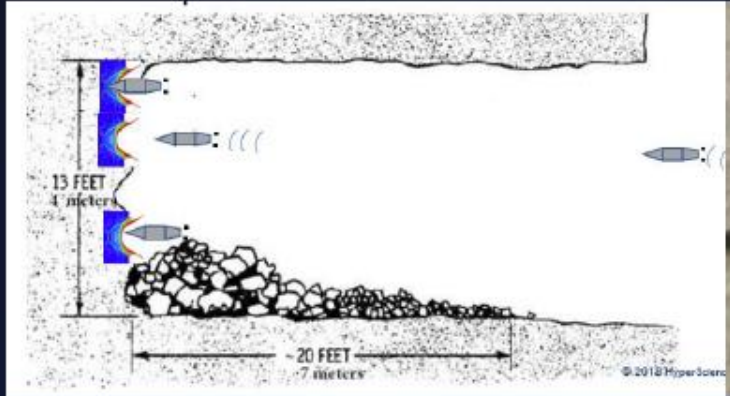
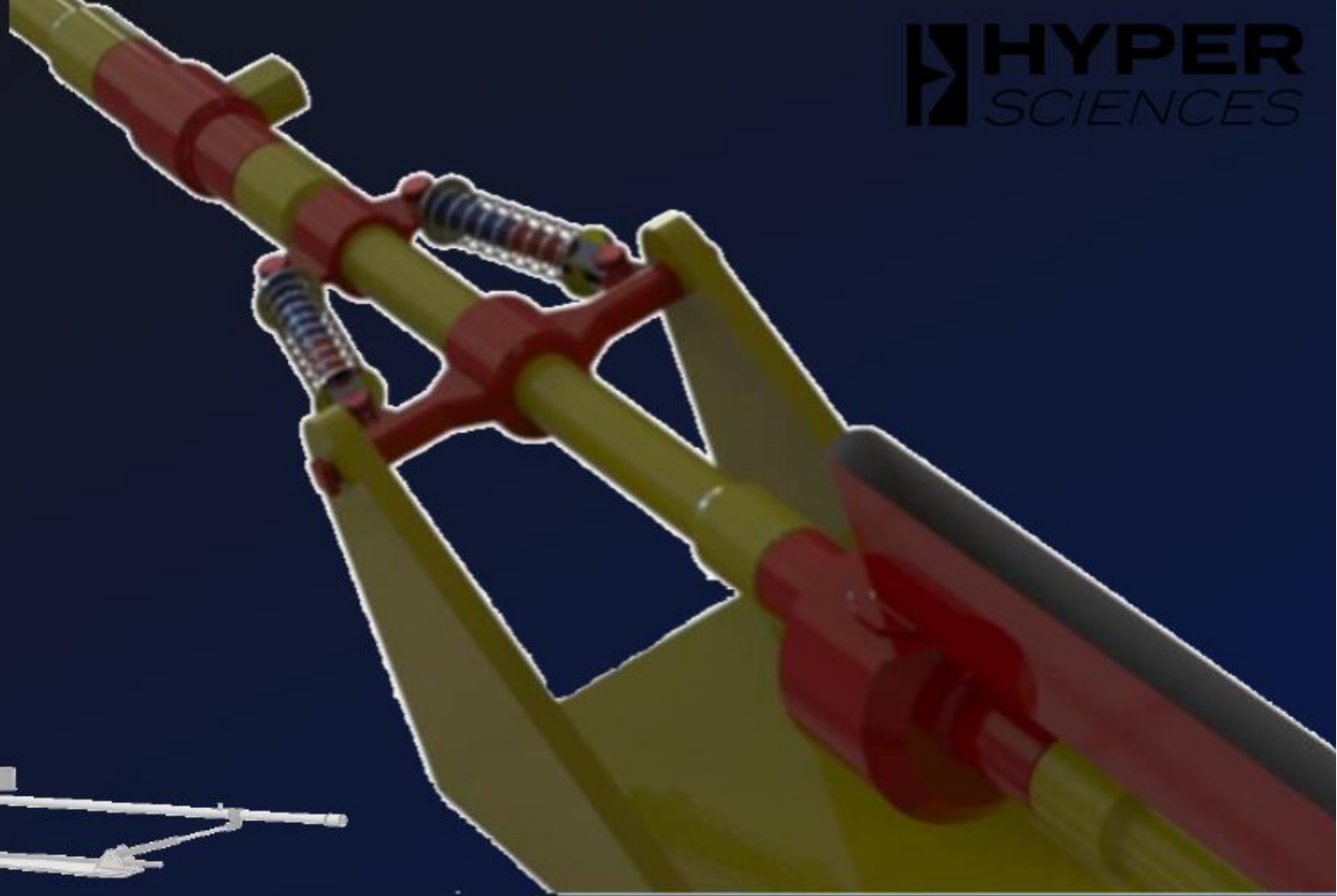

© 2018 HyperSciences

Shell Contract / Path



GameChanger

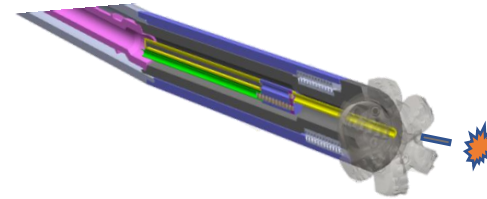
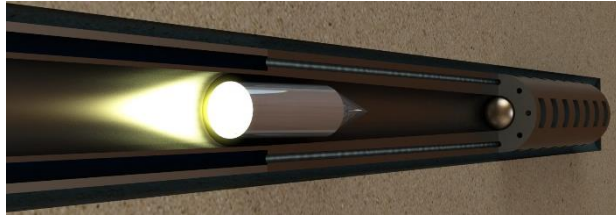

PHASE 1	Complete	PHASE 2	Complete	PHASE 3	Complete
"Feas. Study: Drill Hole On Paper" report (DWOP)		Drill actual hole based on Phase 1 findings		Down-hole MVP tool design. OG&Geo DWOP	

- **Drill horizontal hole**
- Commission prototype at MineLab silver mine (N. Idaho)
- **Simulate drilling at depth**
- Conduct test shots using stressed rock targets (simulated pressure environment) SWRI
- **System integration**
- Evaluate solutions for HSSE, blowout prevention, cuttings removal, cementing, casing, etc.
- **Define MVP (Min. Viable Product)**
 - Down-hole tool & Drill well on paper exercises to support Series A due diligence (September 2016)
 - **Oil & Gas Engineered Geothermal – New Energy Opportunities**

Proof Points

Hypervelocity Testing

Thousands of hypervelocity experiments completed by HSI team.

Bore sizes: 0.5", 1.5", 4"
Most experiments done in 1.5-2.7 km/s range



Rock Impact Testing

Hundreds of tests done in rock types of interest at downhole conditions (saturated samples under confining pressures > 3000 psi)



Model Correlation

Hydrocode models predict penetration characteristics and have been calibrated by Shell experiments. ROP proof.

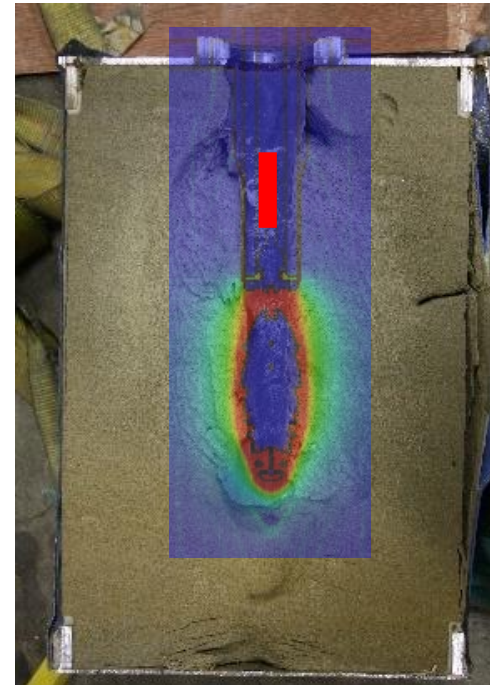

CONTACT INFORMATION:

FOR FURTHER INFORMATION,:

Mark Russell, CEO

+1 (509) 994.8577

mark@hypersciences.com