

Dynamic Imaging Analysis for Drilling Mud Profiling

Tod Canty, Ciarán Dunne and Colin Dalton, JM Canty

Copyright 2020, AADE

This paper was prepared for presentation at the 2020 AADE Fluids Technical Conference and Exhibition held at the Marriott Marquis, Houston, Texas, April 14-15, 2020. This conference is sponsored by the American Association of Drilling Engineers. The information presented in this paper does not reflect any position, claim or endorsement made or implied by the American Association of Drilling Engineers, their officers or members. Questions concerning the content of this paper should be directed to the individual(s) listed as author(s) of this work.

Abstract

In rotary drilling operations drilling mud is used to assist the drilling of boreholes and carry cuttings out of the hole. Specific properties of the drilling mud including emulsion stability, component concentrations, and solid particle size distribution must be constantly monitored to prevent process upsets such as aqueous phase coalescence, water instability, and gas pocket back pressure incidents. Drilling mud is typically analyzed by taking samples off line and measuring the characteristics with unique methodologies. These include electrical stability analysis for emulsion stability indication, retort testing for concentration data, and FBRM laser diffraction or dynamic light scattering for particle size analysis. The offline nature of these methods as well as the high intensity workflows required impose considerable limitations. The development of dynamic microscopic imaging technology has arisen as a powerful tool for liquid particle and component analysis in drilling mud. This paper discusses the advantages of employing a Canty image-based analyzer for drilling mud profiling, with the ability to determine all of the above mentioned characteristics with one homogenized test method and analyzer.

Introduction

Drilling muds or fluids can be defined as complex aqueous or oil-based suspensions that are designed and employed in a rotary drilling oil extraction process to fulfill a number of vital functions. Chief among these are cooling and cleaning of the drill bit during operation, maintenance of hydrostatic pressure in a well bore, drill cutting removal, suspension of drill cuttings during a paused process, and the prevention of corrosion and formation damage. The efficacy of drilling mud in carrying out these functions is greatly affected by the properties of the mud itself. The influence of mud property variations on the functionality of drilling mud is widely understood and thus, efforts must be taken to analyze the drilling mud for constant data feedback on the drilling mud profile (Salathiel, 1952).

Dynamic imaging based analysis is a unique method for drilling mud analysis in that it is not affected by many of the limitations that other time consuming, error prone tests are hampered by. In the case of particle size analysis, sizing systems traditionally relied on methods such as FBRM laser diffraction or dynamic light scattering. These are laser-based tests that report a one-dimensional measurement not indicative of true particle shape or size. Imaging microscopy has been a major innovation in the field of particle size analysis and allows

for detailed two-dimensional particle size and shape analysis. The Canty image-based particle size analyzer has championed this method of particle analysis and brought it to the field of drilling mud. This has enabled detailed particle size composition analysis for mud in rotary drilling applications. The vision-based technique operates around the basic principle of presenting a sample fluid between a high intensity light source and a high-resolution microscopic camera. Images are captured of both particles and droplets from the liquid suspension as they are presented to the camera. The proprietary software then distinguishes between images captured and classifies them as oil/water droplets, gas bubbles or solid particles that are all analyzed to output a number of parameters such as facilitating size, shape, and concentration data. A Canty particle analyzer is not limited to particle size distribution (PSD) outputs for drilling mud analysis. The purpose of this paper is to present the functional ability of the Canty dynamic imaging-based analyser for on-line employment in rotary drilling applications to output detailed drilling mud profiles.

Drilling Fluid Composition

As mentioned above, monitoring the specific component characteristics of a drilling fluid are crucial to ensure the drilling process is operating at peak commercial operation and safety. The stability of the emulsion in water-in-oil based muds is critical to prevent water flux and coalescence of the aqueous phase. The exact concentrations of the oil, water, and solid particulate portions of the fluid need to be determined exactly and consistently. Simple one-time measurements are insufficient due to the effect of particle size breakdown. Further to this, the exact PSD need to be accurately measured as the suspended particles help to bridge porous rock formations and plug any fractures to protect against lost circulation.

Emulsion Stability

The stability of emulsion in both oil and water-based drilling mud is of paramount import to both the efficiency and the safety of a rotary drilling process. Oil-based muds can be classified as water-in-oil emulsions that are principally composed of a weighting material combined with an organophilic clay. The aqueous phase is typically a salt solution with a concentration that is set to match the water activity of the formation (Growcock et al., 1994). The concentration and composition of the water phase in oil-base mud determines its ability to solve the hydratable shale problem, minimize the transfer of water to between water sensitive zones and maintain a stable well-bore.

The external phase of oil-based mud is oil and does not allow the water to contact the formation; the shales are thereby prevented from becoming wet with water and dispersing into the mud or caving into the hole. The stability of an emulsion mud is an important factor that has to be closely monitored while drilling. Poor stability results in coalescence of the dispersed phase, and the emulsion will separate into two distinct layers. Presence of any water in the filtrate is an indication of emulsion instability.

The emulsion stability of an oil-based mud is typically measured based on the mud's electrical stability. These test methods employ sine wave electrical stability instruments. A precision voltage-ramped sinusoidal signal is applied across a pair of parallel flat plate electrodes that are immersed in the drilling mud. Dynamic image-based analysis can provide an alternative method for determining emulsion stability by detailing the droplet profile of the emulsion. The size distribution of the droplets in the emulsion will give a detailed insight into the state of the emulsion itself. Larger droplets will have an increased likelihood to coalesce, dropping out of the emulsion and tending towards a separation into a distinct aqueous layer. Smaller, more numerous droplets will be less likely to interact and will stay in suspension. A detailed size distribution and concentration analysis of the droplets present in the emulsion can thus give an accurate read-out of the overall stability of the emulsion. An imaging system provides the added benefit of distinguishing solid particles from droplets, discounting the solid particulate of the mud from the analysis of the emulsion stability.

Fluid Component Concentration

Accurate determination of the specific concentrations of the oil, water and solid particle constituents of drilling fluid is crucial, without these measurements the action of the drilling fluid in the well-bore cannot be effectively predicted. Each of these components serves a specific function to the drilling operation. The water concentration is vital as a weighting agent, it must be present at significantly high levels to counteract the pressure kickbacks of gas pocket exposures. It must also be sufficiently concentrated to ensure a water balance between the mud and the various shale sections (Chenevert, 1970). The solid particulate facilitates plugging of fractures to prevent circulation loss and the bridging of porous rock formations. The oil serves as the continuous phase of the drilling mud. The knowledge of the oil, water, and solid content is fundamental when considering oil/water ratios, rheology, density, filtrations and salinity.

Traditionally, concentration measurements are obtained using the standard retort method. This employs a high intensity, offline workflow whereby a known volume of sample is heated, vaporizing the liquid components which are then condensed and collected in a graduated receiver tube. Liquid volumes are determined from reading the oil and water phases on the graduated cylinder. The total volume of solids, both suspended and dissolved, is obtained by noting the difference of the total sample volume versus the final liquid volume collected. Calculations are necessary to determine the volume of suspended solids since any dissolved solids will be retained in

the retort. The principal limiting factors of this method are the time taken and the offline nature of the test. A question can also be raised as to how well an offline sample analysis correlates to the actual reading from the inline process. The Canty imaging microscopy-based analyzer can be installed inline to give continuous, accurate real-time reads on the specific concentrations of the drilling fluid components. In this case no manipulation of the fluid is required.

Particle Size Distribution

The function of the solid particle component of drilling mud has already been stated. The importance of the particulate functionality necessitates both the comprehensive research to determine the best solids employed and the constant, detailed determination of the state of the particles in the drilling fluid. Selecting and maintaining the right PSD for downhole fluid loss/lost circulation conditions is essential and of overriding importance compared to the type of particles for optimum drilling performance. The PSD of a drilling fluid will shift over time due to attrition and the influence of shear degradation (van Oort et al., 2016). As the particles degrade over time the PSD shifts towards smaller particles. It is thus necessary to obtain constant detailed inline reports on the particle composition of the drilling mud. A number of particle analyzers exist for this purpose that employ FBRM laser diffraction or dynamic light scattering. In these applications a one-dimensional reading is obtained as a particle interrupts the beam of a laser. The derived shape of the particle is determined by using this measurement of the size dependent property and relating them to a single dimension. The equivalent spherical diameter is a prominent method in these applications. This method equates a diffracted light intensity to a spherical volume that is reported as the volume of that particle. It can be seen intuitively that this cannot achieve the accuracy that is possible with an imaging microscopy system that can capture and report a two-dimensional image of a particle, facilitating detailed shape and size analysis. For this reason, the Canty analyzer demonstrates a clear advantage when it comes to obtaining the PSD of a drilling fluid.

Canty Imaging Based Analysis

The Canty dynamic imaging particle analyzer has untapped potential for integration as the principle system for detailed analysis of emulsion stability, mud component concentrations and drilling mud PSDs, as has been discussed above. The system has become one of the most prominent tools for accuracy and ease of online integration in particle sizing applications which have facilitated the diversification of the system's capabilities. The development of an online automatic sampling rig (Figure 1) allowed for the installation of the unit into the line of a process. The system can then output data over 4-20 mA and open connectivity for process control (OPC) to an operator DCS. The high-resolution camera within the analyzer has the ability to capture high fidelity images of the particles that can be saved to allow for visual qualification of the data (Figure 2). The visual acuity of the system also facilitates the distinction between different classes of particulate. Water

droplets that would normally influence the solid particulate PSD obtained with other instruments can thus be discounted and analyzed separately (Figure 3). Repeatability is achieved due to the minimal workflow and manipulation of the sample that is required, all that is needed is a volume of the sample liquid to be passed through the flow cell of the analyzer. The reproducibility has been demonstrated and can be seen in Figure 4. These attributes clearly indicate the Canty analyzer as the ideal tool for drilling mud analysis.

Figures

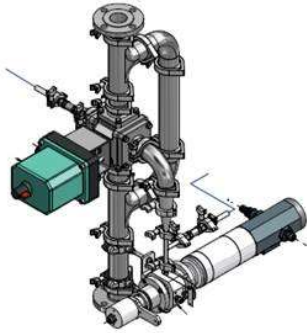

Figure 1: Canty particle analyzer installation drawing with the automated sampling unit. Pictured in green is the automated actuator valve, while the analyzer is shown in the bottom right quadrant.

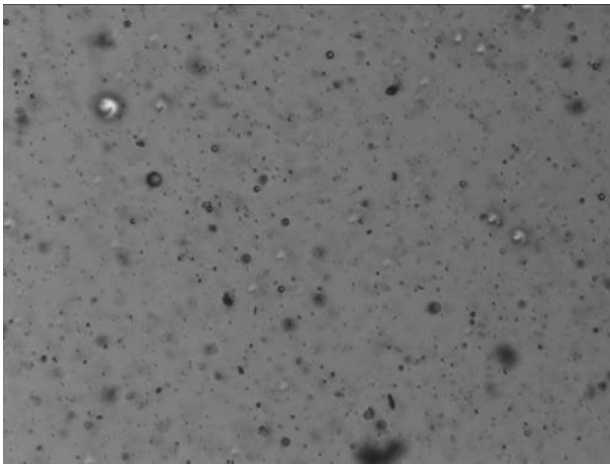

Figure 2: Typical images captured during analysis of water droplets and solid particulate in oil-based drilling mud.

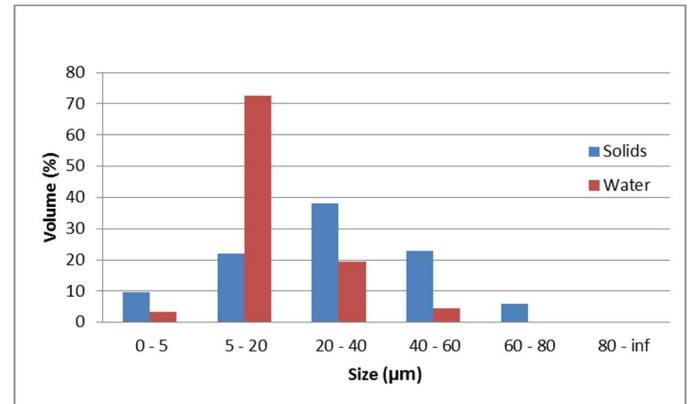

Figure 3: Typical solid and water distribution data obtained with the canty imaging-based analyzer.

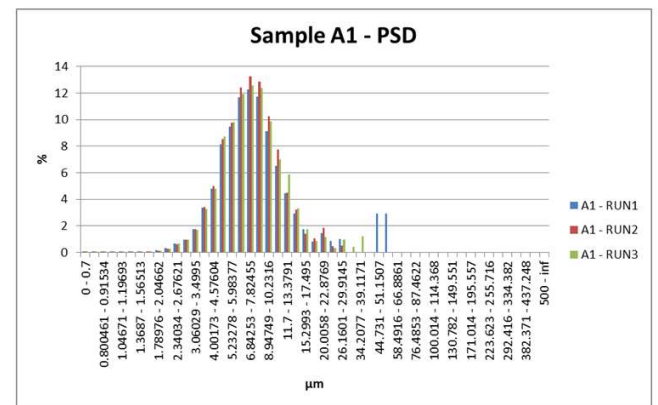

Figure 4: Example PSD data outputs of a sample obtained using the Canty analyzer. PSD reported here is volumetrically weighted.

Conclusions

The importance of understanding the specific characteristics of a drilling mud have been outlined above. In order to ensure the safety and functional efficacy of a rotary drilling operation steps must be taken to determine the state of the drilling mud emulsion stability, the specific concentrations of the mudflow constituents as well as the exact particle composition. Traditionally these analyses were conducted individually using the distinct methods outlined above in this paper. Samples are taken for a retort test to determine oil, water and solid concentrations, tested for electrical stability as an indicator of emulsion stability and tested for PSD using FBRM laser diffraction or dynamic light scattering. This separates mud profile analysis and requires a number of different workflows. While this methodology has proven effective and become the standard for the industry, it does not hold up with regard to modern analytical innovations. The advent of dynamic imaging-based microscopy has influenced a drive for more in-depth, easier to use systems that can achieve the same results. The Canty analyzer has risen as the prominent dynamic imaging analyzer on the market. With this device installed, emulsion stability, Component concentrations and PSD analysis can all be obtained with the same analyzers. This would homogenize the workflow and eliminate any variance that arises as a result of off-line analytical methods.

References

1. Chenevert, M. E. "Shale control with balanced-activity oil-continuous muds." *Journal of Petroleum technology* 22, no. 10 (1970): 1-309.
2. Growcock, F. B., C. F. Ellis, D. D. Schmidt, and J. J. Azar. "Electrical stability, emulsion stability, and wettability of invert oil-based muds." *SPE Drilling & Completion* 9, no. 01 (1994): 39-46.
3. Oort, Eric van, Besmir Buranaj Hoxha, Lin Yang, and Arthur Hale. "Automated drilling fluid analysis using advanced particle size analyzers." In *IADC/SPE Drilling Conference and Exhibition*. Society of Petroleum Engineers, 2016.
4. Salathiel, R. A. "A New Additive for Control of Drilling Mud Filtration." *Journal of Petroleum Technology* 4, no. 03 (1952): 85-90.